



**I N S T A L L E R   G U I D E**



**MODEL 473**  
**Room Sealed**  
**Radiant / Convector**  
**Gas Fire**  
*Black Beauty Unigas II*

***Please keep in a safe place for future reference***

**Please leave this Installer Guide with the user**

This appliance is for use with natural gas (G20)  
This appliance is for use in the United Kingdom  
(GB) and the Republic of Ireland (IE) only.

**C U S T O M E R C A R E**

This Installer Guide gives sufficient details to enable the appliance to be installed and maintained. If further information is required, our **Valor AdviceLine** will be pleased to help.

**Please telephone 0345 626341** (In UK local call rates apply)

# C O N T E N T S

|  | <b>Page</b> |
|--|-------------|
| <b>Specification</b>                       | <b>4</b>    |
| <b>Installation Conditions</b>             | <b>4</b>    |
| <b>Unpacking</b>                           | <b>6</b>    |
| <b>Preparing the Fire</b>                  | <b>6</b>    |
| <b>Preparing the Wall</b>                  | <b>6</b>    |
| <b>Preparing the Flue Unit</b>             | <b>8</b>    |
| <b>Terminal Guard Fitting</b>              | <b>9</b>    |
| <b>Ignition Spark Check</b>                | <b>9</b>    |
| <b>Gas Supply Connection</b>               | <b>9</b>    |
| <b>Fitting Coals</b>                       | <b>10</b>   |
| <b>Operation Check</b>                     | <b>12</b>   |
| <b>Reference Pressure Check</b>            | <b>13</b>   |
| <b>Outer Case Fitting</b>                  | <b>13</b>   |
| <b>Final Checks &amp; User Instruction</b> | <b>13</b>   |
| <b>Servicing</b>                           | <b>14</b>   |
| • <b>Outer Case Removal</b>                | <b>14</b>   |
| • <b>Window Unit Removal</b>               | <b>14</b>   |
| • <b>Ceramic Fuels Removal</b>             | <b>14</b>   |
| • <b>Burner(s) Removal</b>                 | <b>14</b>   |
| • <b>Injector(s) Removal</b>               | <b>14</b>   |
| • <b>Thermocouple Removal</b>              | <b>14</b>   |
| • <b>Electrode Pin Removal</b>             | <b>14</b>   |
| • <b>Pilot Pipe &amp; Jet Removal</b>      | <b>14</b>   |
| • <b>Gas Tap Unit Removal</b>              | <b>15</b>   |
| • <b>Piezo Generator Removal</b>           | <b>15</b>   |
| • <b>Gas Tap Greasing</b>                  | <b>15</b>   |
| • <b>Short Spares List</b>                 | <b>16</b>   |

# 1. SPECIFICATION

The overall dimensions are shown in figure 1.

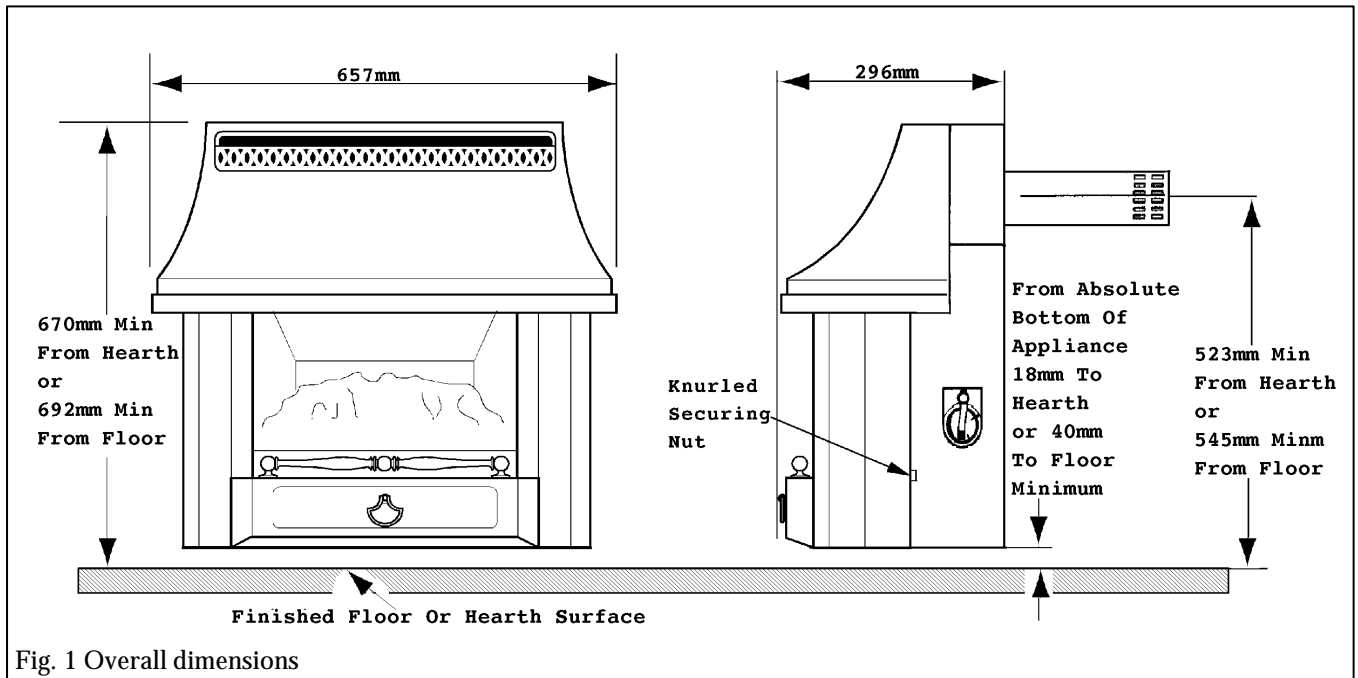

Fig. 1 Overall dimensions

|                               |                               |                                 |  |
|-------------------------------|-------------------------------|---------------------------------|--|
| <b>Gross Weight:</b>          | 26.2kg                        | <b>Flame Effect Burner:</b>     | Bray Cat. 960 Size 130   |
| <b>Main Burner:</b>           | Simplex aerated               | <b>Pressure Setting (Cold):</b> | 18.2 ± 0.75mbar  |
| <b>Flame Effect Burner:</b>   | Simplex aerated.              | <b>Aeration Adjustment:</b>     | None required.   |
| <b>Gas Connection:</b>        | RP 1/4 (1/4in. B.S.P) Female. | <b>Control Tap:</b>             | Variable position fitted with flame supervision device and integral piezo igniter. |
| <b>Gross Gas Consumption:</b> | 4.9kW at maximum position.    | <b>Pilot Unit:</b>              | Right side of firebox.   |
| <b>Maximum output:</b>        | 3.54kW                        |                                 |  |
| <b>Injectors:-</b>            |                               |                                 |  |
| Main Burner:                  | Bray Cat. 960 Size 240.       |                                 |  |

No component on this appliance is manufactured from asbestos or asbestos related products. The appliance data label is at the left side of the rear case and is visible after removing the case front. In addition, for customers reference, there is a label giving the appliance serial number on the outside of the case at the bottom right side.

# 2. INSTALLATION CONDITIONS

This product uses fuel effect pieces, burner compartment walls and gaskets containing Refractory Ceramic Fibres (RCF), which are man-made vitreous silicate fibres. Excessive exposure to these materials may cause temporary irritation to eyes, skin and respiratory tract. Consequently, it makes sense to take care when handling these articles to ensure that the release of dust is kept to a minimum. To ensure that the release of fibres from these RCF articles is kept to a minimum, during installation and servicing we recommend that you use a HEPA filtered vacuum to remove any dust and soot accumulated in and around the fire before and after working on the fire. When replacing these articles we recommend that the replaced items are not broken up, but are sealed within a heavy duty polythene bag, clearly labelled as RCF waste. This is not classified as “hazardous waste” and may be disposed of at a tipping site licensed for the disposal of industrial waste. Protective clothing is not required when handling these articles, but we recommend you follow the normal hygiene rules of not smoking, eating or drinking in the work area and always wash your hands before eating or drinking.

## 2.1 Walls:-

Minimum 102mm (4in.) thick

Maximum 660mm (26in.) thick.

Suitable for use with combustible walls provided that there is no combustible material or combustible cladding in the area indicated on the wall fixing template.

*Please note that soft wall coverings (e.g. embossed vinyls etc.) are easily affected by heat. They may therefore, scorch or become discoloured when close to a heating appliance. Please bear this in mind when installing.*

**2.2** Where installation is into a timber framed house, this should be in accordance with Paragraphs 5.2, 5.3, 5.4, 5.5, 5.6, and 6.1 of British Gas publication ‘Dm2 Guide For Gas Installations In Timber-Framed Housing’.

**2.3** The installation must be in accordance with these instructions.



|   | <b>Terminal Position</b>  | <b>Minimum Distance (mm)</b> |
|---|---|------------------------------|
| A | Directly below an openable window or other opening e.g. air brick | 300                          |
| B | Below gutters, soil pipes or drain pipes                          | 300                          |
| C | Below eaves   | 300                          |
| D | Below balconies or car port roof                                  | 600                          |
| E | From vertical drain pipes and soil pipes                          | 75                           |
| F | From internal or external corners                                 | 600                          |
| G | Above ground, roof or balcony level                               | 300                          |
| H | From a surface facing a terminal                                  | 600                          |
| I | From a terminal facing a terminal                                 | 600                          |
| J | From an opening in a car port (e.g. door, window) into dwelling   | 1200                         |
| K | Vertically from a terminal on the same wall                       | 1500                         |
| L | Horizontally from a terminal on the same wall                     | 300                          |

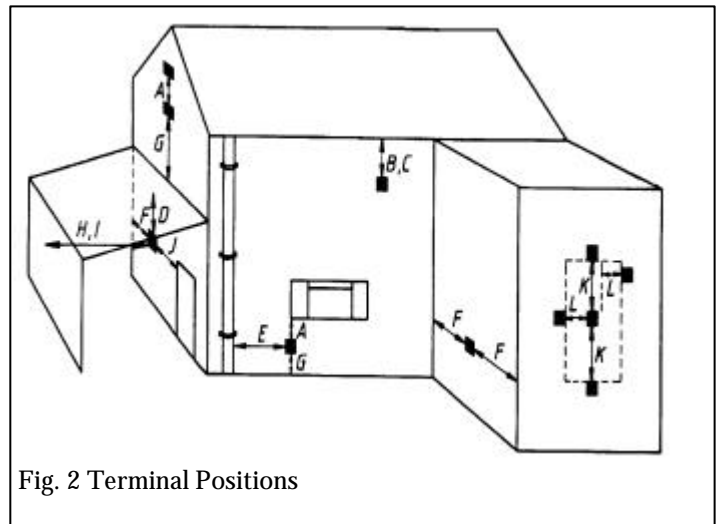

#### 4. PREPARE THE FIRE

- 4.1 Stand the fire upright
- 4.2 Detach the case front by removing the knurled nuts and washers at the case sides (see fig.1).
- 4.3 Pull the bottom of the case forwards and then left to remove.
- 4.4 Remove the window unit by detaching the 12 wing nuts securing the window frame (see fig.3) and pulling forward.

## 5. PREPARE THE WALL

The flue must be installed so that it is at right angles to the back panel of the fire all round the flue circumference. The fire itself should be fitted vertically against a flat wall. Where this is difficult to achieve due to building inaccuracies care should be taken to ensure that the back of the fire is not stressed in any way due to distortion of the assembly when tightening the fixing screws. Where necessary, non-combustible packing pieces should be used to provide a satisfactory fixing surface.

Before cutting the hole in the wall make sure that the height to the top surface of the finished floor is known. The minimum acceptable height from this surface to the flue hole centre is shown in figure 4. If a loose hearth or plinth is to be used, the height from its top surface must be used when determining the minimum flue height. Where installation is to a timber frame wall, the appliance should be positioned so that the right side wall fixings are into timber studs to absorb any pressure generated by operating the control knob.

Proprietary cavity fixings should be used at the left side if the fixing at this side is into plasterboard.

**5.1** Place dust sheets on the floor and over any furnishings etc.

**5.2** Place the template against the wall. Make sure that the centre of the flue hole is not less than the minimum shown in figure 4.

**5.3** Pierce the centre of the screw fixing holes and the flue hole and mark the positions on the wall. Remove the template.

**5.4** Cut the hole for the flue unit. Make sure that it is straight and level. Though a hammer and chisel can be used, using a core drill is by far the quickest and simplest method for normal brickwork.

### 5.5 Core Drilling

**5.5.1** Drill a pilot hole through the wall. Inspect the hole to ensure that it is in the brickwork and not in mortar. If it is in mortar, it is advisable to reposition the hole approximately 25mm away (making sure that the minimum side clearances and height are complied with). Remember to reposition the screw fixing holes.

**5.5.2** Drill the flue hole with a 6in. (152mm) core drill. Where practical, it is recommended that the hole is drilled from inside the building to about half the wall depth with the remainder drilled from outside. This ensures that the edges of the hole are clean on both sides.

### 5.6 Hammer & Chisel Cutting

**5.6.1** Mark a 152mm (6in) diameter circle for the flue hole. Chisel out the area marked.

**5.6.2** It may be necessary to make good both the internal and external wall faces. To achieve a neat finish and to make any future removal of the flue unit easier, it is recommended that a cardboard cylinder is formed around the flue unit and inserted in the hole while making good. Remove the cardboard cylinder after making good.

**5.7** Recheck the screw fixing holes relative to the flue hole.

**5.8** Drill the four fixing holes to a minimum depth of 42mm using a 7mm diameter masonry drill.

**5.9** Insert the four wall plugs supplied.

**5.10** Remove any combustible wall cladding material from the area shown in figure 5.

**5.11 Leaving a Hole, Building under Construction**

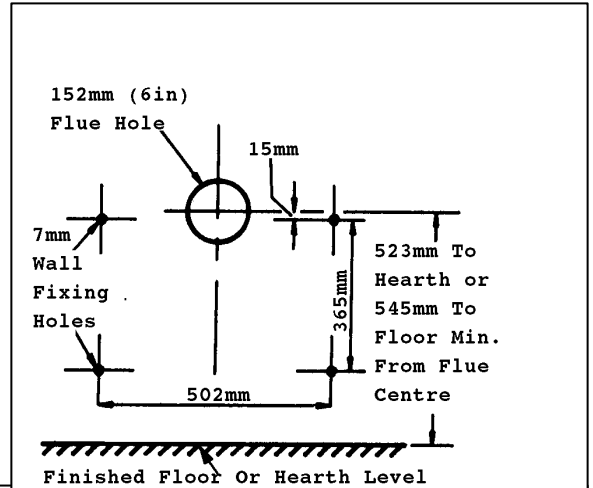

Fig. 4 Wall Drilling

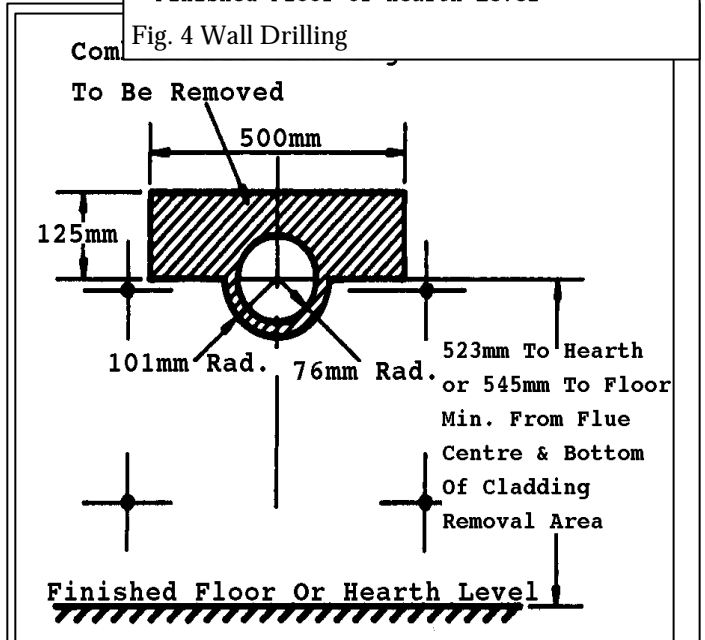

Fig.5 Combustible Cladding Removal

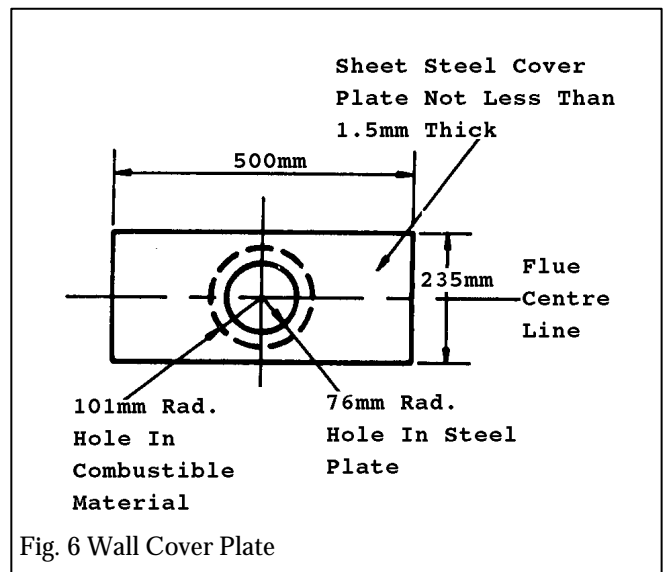

Fig. 6 Wall Cover Plate

It will be convenient to use a non-corrosive metal tube 160mm diameter built into the wall at the correct position for the flue unit.

**5.12 Combustible Walls (Wood, Fibreboard, Plasterboard etc.)**

Building regulations require that the inlet and outlet ducts and terminal must not be closer than 25mm to combustible material.

**5.12.1** Mark out and cut a hole 202mm diameter through the combustible part of the wall. A 152mm diameter hole can be cut through non-combustible parts of the wall (see figure 6).

**5.12.2** Cover the hole with a square sheet steel plate 500mm x 235mm with a 152mm diameter hole cut out of the centre (see figure 6). The steel should be not less than 1.5mm thick. Fix with suitable screws and plugs.

**5.12.3** Where the whole wall is of combustible material, a non-corrosive plate 455mm x 455mm with a 152mm diameter hole in the centre must be fitted to the outer wall. The hole through the wall should be lined with a non-corrosive metal tube 202mm diameter.



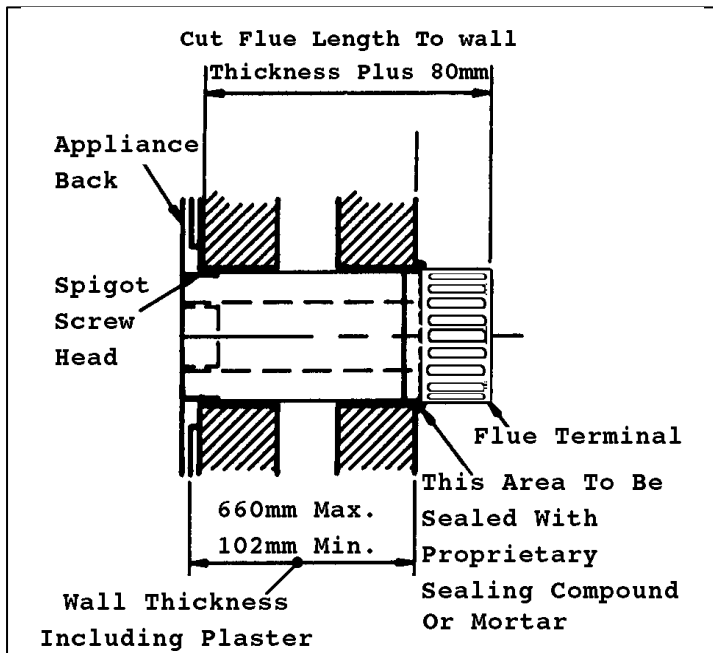
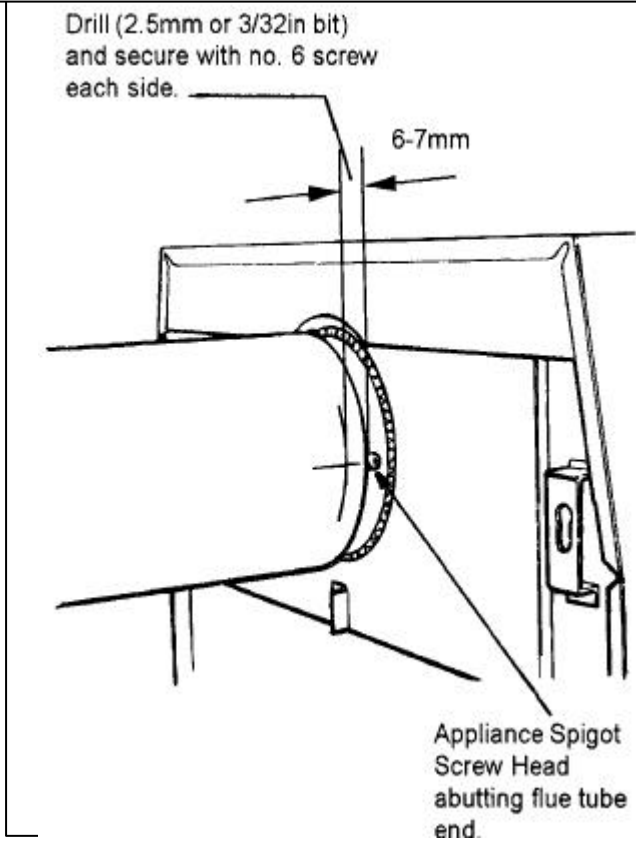

Fig. 7 Flue Unit Dimensions



## 6. PREPARE FLUE UNIT (Figure 7)

**6.1** Measure the total wall thickness from the outside surface to the inside face. Add 80mm to this measurement to obtain the correct length of flue unit required.

**6.2** Mark off the flue length on the outer (air) tube measuring from the end of the terminal.

**6.3** Insert the polystyrene ring between the inner and outer tubes to support them and cut both tubes squarely at the marked distance.

**6.4** *Important: Remove all polystyrene from the flue unit after cutting.*

**6.5** Fit the flue unit tubes firmly over the spigots at the rear of the fire. Make sure that the seam on the flue tube is not at the bottom. Push on until the outer tube touches the screw heads on the outer spigot.

**6.6** If it is felt of benefit, the flue unit may be additionally secured to the fire with one or two suitable self tapping screws (we suggest No.6) before installing into the wall as follows:-

**6.6.1** Using a suitable metal cutting drill bit, drill through the outer flue tube and outer spigot at a distance of between 6mm & 7mm from the cut end of the outer flue tube - See figure 8.

**6.6.2** Fit the self tapping screw(s) in the drilled hole(s).

**6.7** Seal the flue unit all round the circumference of the fire spigot with the tape supplied.

**6.8** Insert the plugs into the wall fixing holes. Insert the top right fixing screw leaving the plain shank proud to allow the top fixing keyhole in the fire back to go over the screw.

**6.9** Offer the fire complete with flue unit through the wall and hook the top right keyhole slot over the previously fitted wall screw.

**6.10** Insert the top left and two bottom fixing screws and tighten.

**6.11** Seal, the outer flue tube to the outside surface of the wall with fireclay or cement. Make sure that the slots in the flue terminal are not closer than 8mm to the wall and are not obstructed by cement.

## 7. TERMINAL GUARD FITTING

**7.1** Place the guard centrally over the flue terminal with the fixing ears at each side - not at the top and bottom (see figure 9).

**7.2** Holding the guard in position and using it as a template, mark on the wall the positions of the four fixing holes.

**7.3** Remove the guard. Drill and plug the holes

**7.4** Replace the guard fixing with suitable screws.

## 8. CHECK IGNITION SPARK

The pilot ignition unit is situated at the bottom right side of the firebox - See figure 10.

Check that there is an ignition spark between the pilot hood and the electrode pin.

**8.1** Depress the control knob and, while keeping it depressed, turn to IGN position. Turning the control should normally cause two consecutive sparks to occur between the pilot hood and the electrode pin.

**8.2** If there is no spark, check that the wire connection is secure.

**8.3** If there is still no spark disconnect the electrode wire from the pilot unit and place the end of the wire close to a bright metal part of the appliance.

**8.4** Operate the control again keeping your hand away from the end of the wire. If there is a spark, the pilot unit is at fault.

**8.5** The spark gap on the pilot unit is non-adjustable. Replace the pilot unit or its components.

**8.6** If there is no spark, the gas tap piezo unit should be changed.

## 9. CONNECT TO THE GAS SUPPLY

**9.1** Extend the gas supply pipe to a convenient point beneath the appliance and connect it to the inlet pipe at the right side of the fire using the Rp1/4 (1.4in. B.S.P) elbow provided.

The supply pipe must be of rigid material (e.g. copper). Flexible connections must not be used.

**9.2** Provision for isolation of the gas supply upstream of the fire must be provided for safety and servicing.

**9.3** Pressure test the installation for gas soundness in accordance with the current edition of B.S.6891.

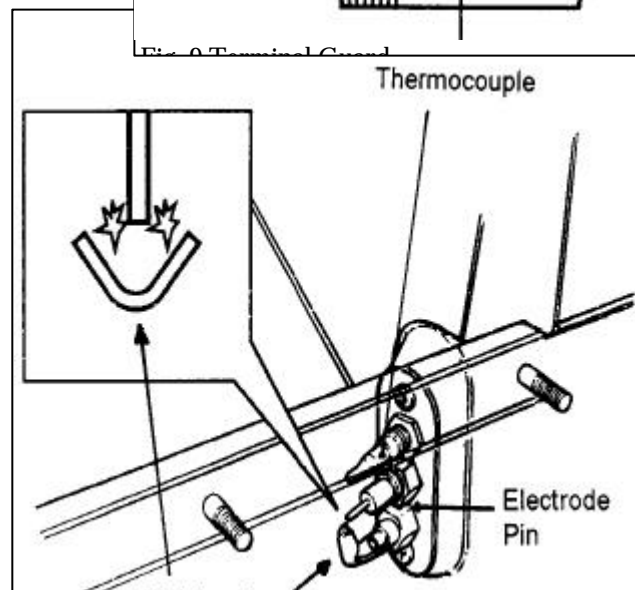
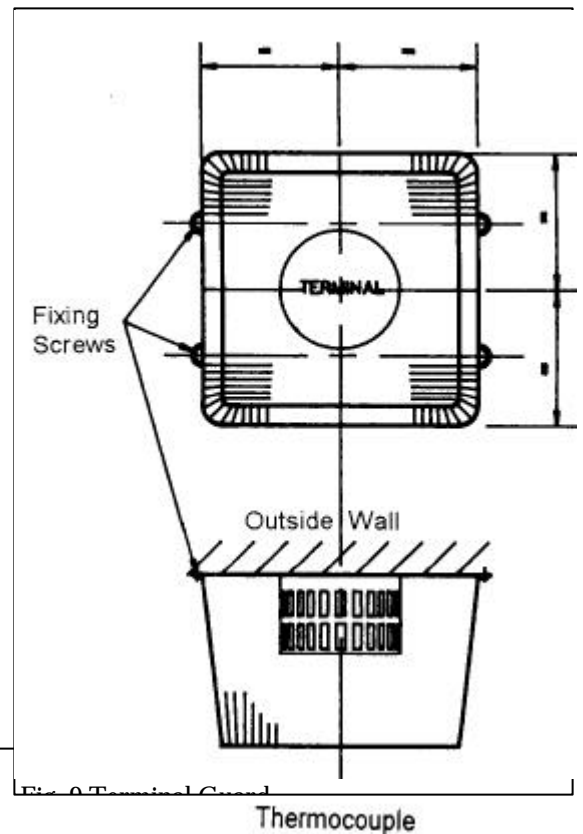

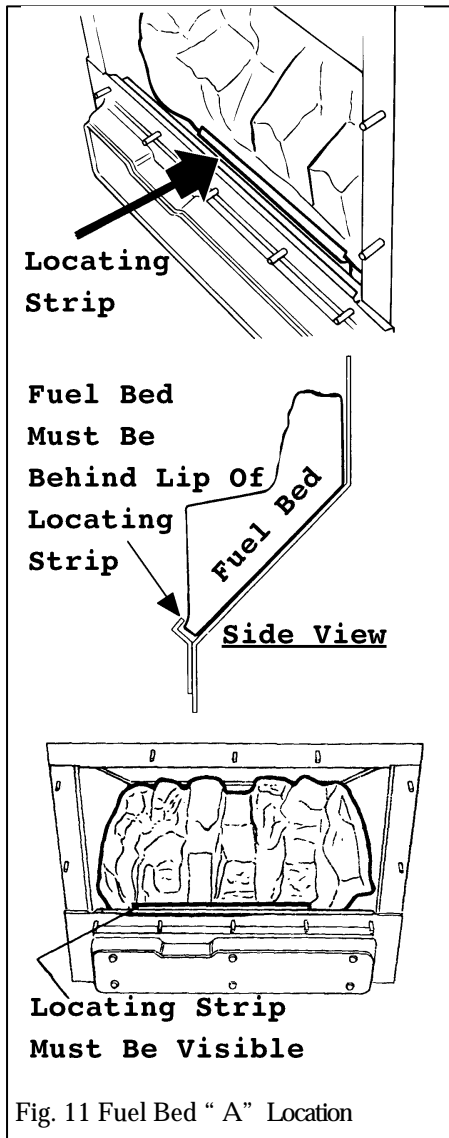

## 10. FIT COALS

**10.1** Place the fuel bed (embossed 'A' underneath) in position. The front edge of the fuel bed locates under the flange of the locating strip at the base of the firebox - see figure 11.

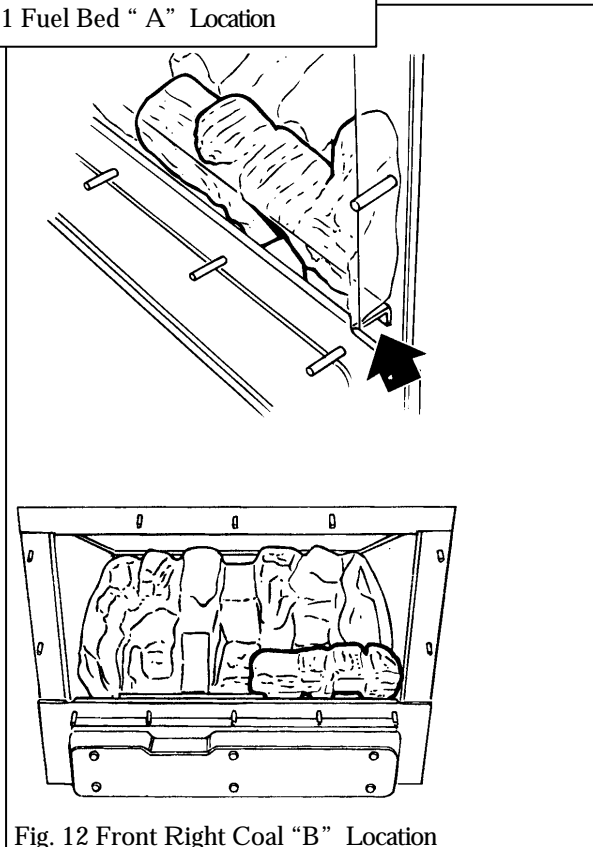

Place the front right coal (embossed 'B' underneath) in position. The flat bottom front face of the coal should rest on the grate immediately behind the bottom front of the firebox. Slide the coal to the right side. See figure 12.

**10.3** Place the front left coal (embossed 'C' underneath) in position at the side of the first coal. The flat bottom front face of the coal should rest on the metal ledge immediately behind the bottom front of the firebox opening. See figure 13.

**10.4** Close any gap between the two front coals by sliding them together to meet at the centre.

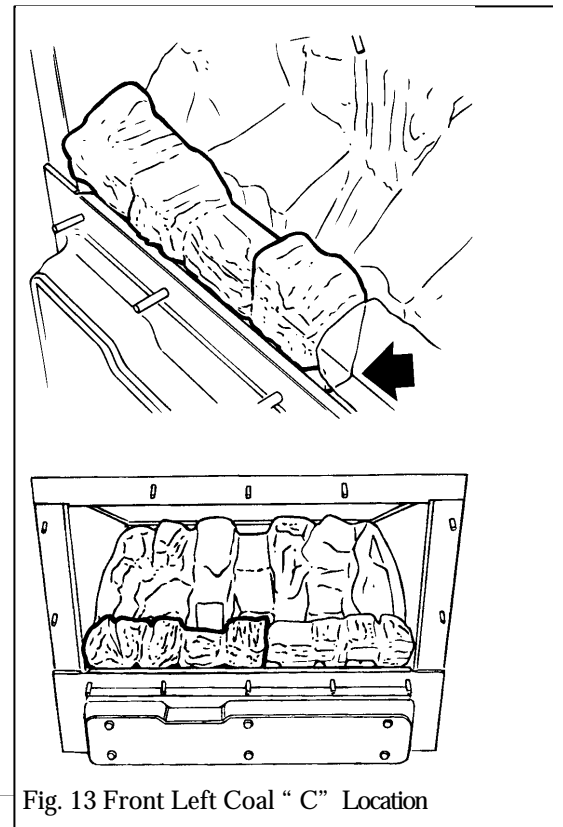

Fig. 13 Front Left Coal " C " Location

**10.5** Place the rear right coal (embossed 'D' underneath) in position shown in figure 14.

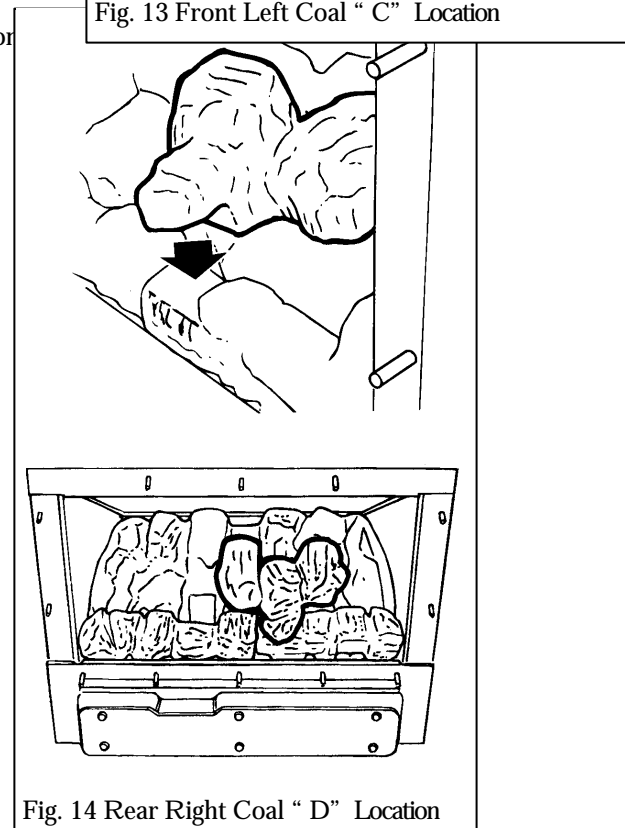
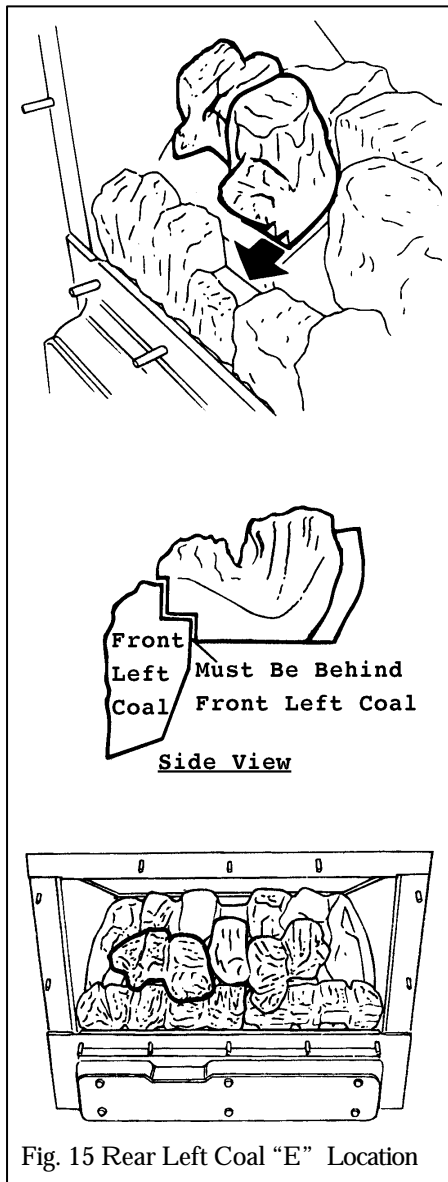

Fig. 14 Rear Right Coal " D " Location



**10.6** Place the rear left coal (embossed 'E' underneath) in position as shown in figure 15.

**10.7** Replace the window unit and tighten the 12 wing nuts.

## 11 CHECK APPLIANCE OPERATION

**11.1** Turn on the gas supply and check all joints up to the appliance gas tap for gas soundness using a soap solution or leak detection fluid.

**11.2** Depress the control knob. While keeping it depressed, turn to IGN position. Turning the control should normally cause two consecutive sparks to occur between the pilot hood and the electrode pin which should ignite the pilot gas.

The pilot flame can be seen by looking through the gap at the front of the right side front coal.

If the pilot does not ignite, keep the knob depressed for a few seconds to purge air from the supply pipes, then, turn back to OFF and repeat the ignition procedure.

**11.3** When pilot ignition has been achieved, keep the control knob depressed for a few seconds then release it. If the pilot does not remain alight ensure that the air has been purged.

**11.4** Partially depress the knob and turn to position 1. Both main and decorative flame burners should light at the lowest setting. The decorative flames should just be visible. If the decorative flames are visible, the main burner must be alight since it lights the decorative burner.

**11.5** Turn the control knob gradually to MAX position. Both burners should gradually increase in output until at MAX position the main burner is at its greatest heat output and the decorative flames are at their full magnitude.

**11.6** Turn back to off after checking.

Depress the control knob partially, turn clockwise to OFF and release the knob. If any resistance is felt when turning, release the downwards pressure on the knob before continuing to turn.

## **12 CHECK THE REFERENCE PRESSURE**

The burner aeration is non-adjustable. The appliance is preset to give the correct heat input on Natural Gas at 20 mbar (8in w.g) inlet pressure and no further adjustment is necessary. The burner pressure should be checked at the pressure test point located on the pipe connecting the gas tap to the main burner. The pressure check should be carried out using a calibrated pressure gauge after removing the test point screw. The fire should be alight and the control knob at MAX setting. The pressure setting should be within the limits shown in the appliance specifications - see section 1. After checking the pressure, turn off the fire, remove the pressure gauge and replace the pressure test sealing screw. Relight the fire and test all gas joints for soundness using a suitable leak detection fluid.

## **13 REPLACE OUTER CASE**

**13.1** Lower the outer case into position with its top rear rim behind the vertical flange at the top of the ear case and with the outer case bottom angled forward slightly. Then, ease the case bottom inwards to engage the fixing studs through the holes in the rear case.

**13.2** Secure the case with the two knurled nuts and washers.

## **14. MAKE FINAL CHECKS AND INSTRUCT USER**

**14.1** Recheck the pilot ignition and operate the fire through the range of settings.

**14.2** Instruct the user on the correct operation of the fire and especially advise that:

**14.2.1** The fire has a pilot. To light the pilot, the control knob must be depressed and turned to IGN position.

**14.2.2** The pilot flame can be viewed to ensure that it is alight. Show the user where to view the pilot and point out the illustration in the users instructions showing how to view the pilot.

**14.2.3** The pilot can be left alight. Advise, though, that if the premises are to be left unoccupied for a lengthy period, it is advisable to turn the pilot off.

**14.3** Advise the user that the fire may give off a slight odour while new. This is normal and it will disappear after a short period of use.

**14.4** Advise the user that the bright metal firebox will discolour with use.

**14.5** Emphasise that if the glass panel is broken or damaged, the fire should be turned off and not used until the window unit is refitted with an authorised replacement.

**14.6** Recommend that the appliance should be serviced by a competent person (*In the UK a CORGI registered person*) at least annually.

*If the appliance is in premises in the United Kingdom occupied by a tenant, point out that by law a landlord must have any gas appliance, flue and pipework which is situated in a tenant's premises checked for safety at least every 12 months.*

**14.7** Hand over to the customer this guide and the users guide.

## **15. SERVICING**

***Turn off the gas and make sure that the appliance is cool before commencing any servicing  
Always test for gas soundness after refitting the appliance.***

### **15.1 To Remove Outer Case.**

- 15.1.1** Remove the knurled screws at the case sides (see fig.1).
- 15.1.2** Pull the bottom of the case forwards and then lift the case clear.

### **15.2 To Remove Window Unit**

- 15.2.1** Remove the outer case as 15.1 above.
- 15.2.2** Remove the window unit by detaching the 12 wing nuts securing the frame (see fig. 3) and pulling forward.

### **15.3 To Remove The Ceramic Fuel Items**

- 15.3.1** Remove the outer case as 15.1 above.
- 15.3.2** Remove the window unit as 15.2 above
- 15.3.3** Remove the coals carefully
- 15.3.4** Lift out the coal bed
- 15.3.5** Replace the items as described in the installation instructions.

### **15.4 To Remove Burner(s)**

- 15.4.1** Remove the outer case as 15.1 above
- 15.4.2** Remove the window unit as 15.2 above.
- 15.4.3** Remove the ceramic items as 15.3 above.
- 15.4.4** Remove the burner front cover by unscrewing 14 screws.
- 15.4.5** Remove the front ceramic support bar by unscrewing 1 screw each side.
- 15.4.6** Remove the burner(s) by unscrewing one screw at the left side and lifting clear.
- 15.4.7** The main and decorative flame burners are of different lengths. They cannot be fitted in the wrong positions.

### **15.5 To Remove Injectors(s)**

- 15.5.1** Remove the outer case as 15.1 above.
- 15.5.2** Release the pipe compression fitting(s) to the injector(s).
- 15.5.3** Loosen the pipe compression fitting(s) to the tap and move the pipe(s) clear.
- 15.5.4** Remove the injector(s) and carrier(s) from the firebox side.
- 15.5.5** Remove the injector(s) from the carrier(s)

### **15.6 To Remove Thermocouple**

- 15.6.1** Remove the outer case as 15.1 above.
- 15.6.2** Disconnect the thermocouple at the gas tap end.
- 15.6.3** Undo the nut securing the thermocouple to the pilot unit bracket outside the firebox side. Withdraw the thermocouple.

### **15.7 To Remove Electrode Pin**

- 15.7.1** Remove the outer case as 15.1 above.
- 15.7.2** Disconnect the electrode lead at the pilot unit end.
- 15.7.3** To gain access to the electrode nut, disconnect the thermocouple at the pilot unit end as 15.6.3 above.
- 15.7.4** Undo the nut securing the electrode ceramic and pin to the pilot unit bracket.

### **15.8 To Remove Pilot Pipe & Jet**

- 15.8.1** Remove the outer case as 15.1 above
- 15.8.2** Unless the appliance is sufficiently high above the floor to allow access from underneath, remove the thermocouple and electrode pin from the pilot bracket as 15.7.3 and 15.7.4 above.
- 15.8.3** Release the pilot pipe from the gas tap.
- 15.8.4** Unscrew the pilot pipe from the pilot bracket.
- 15.8.5** Carefully withdraw the pilot pipe from the pilot bracket - when withdrawing, the pilot jet will be pulled out.
- 15.8.6** When replacing, make sure that the pilot jet is hooked over the seating at the end of the pipe.

## **15.9 To Remove The Gas Tap And Piezo Unit**

- 15.9.1** Remove the outer case as 15.1 above.
- 15.9.2** Remove the window unit as 15.2 above.
- 15.9.3** Remove the ceramic items as 15.3 above.
- 15.9.4** Remove the burner front cover by unscrewing 14 screws.
- 15.9.5** Remove the control knob by pulling clear of the gas tap spindle.
- 15.9.6** Remove the control bezel by unscrewing 2 screws.
- 15.9.7** Remove the case side and top unit by unscrewing 2 screws at each side near the top and one screw each side near the bottom.
- 15.9.8** Remove the inlet pipe clamp bracket from the case back (one screw).
- 15.9.9** Remove the gas tap bracket from the case (3 screws).
- 15.9.10** Remove the bulkhead plate from the firebox side (3 screws).
- 15.9.11** Lift the manifold unit clear.
- 15.9.12** Disconnect the pipes, thermocouple and bracket from the gas tap.

## **15.10 To Remove The Piezo Generator**

- 15.10.1** Remove the gas tap as 15.9 above
- 15.10.2** Make sure that the tap is in the off position.
- 15.10.3** Remove the circlip holding the piezo unit to the tap. Remove the piezo unit.

## **15.11 To Grease The Control Tap**

- 15.11.1** Detach the tap and remove the piezo generator as 15.10 above making sure that the tap is in the off position.
- 15.11.2** Remove the two screws from the head of the tap. Remove the niting head and spindle complete with collar and spring.
- 15.11.3** Note the position of the slot in the plug - mark its position on the tap body. Remove the plug rotating slightly while pulling.
- 15.11.4** Clean and grease the plug lightly with a suitable grease. Do not apply excessive grease. Particularly, make sure that the gas ports in the tap are not restricted by grease.
- 15.11.5** Push the plug into the tap body and position the slot in line with the mark previously made on the tap body.
- 15.11.6** Reassemble the niting head and spindle complete with collar and spring making sure that the components are correctly engaged. Check the operation of the tap.
- 15.11.7** Refit the piezo generator.



## SHORT LIST OF SPARES

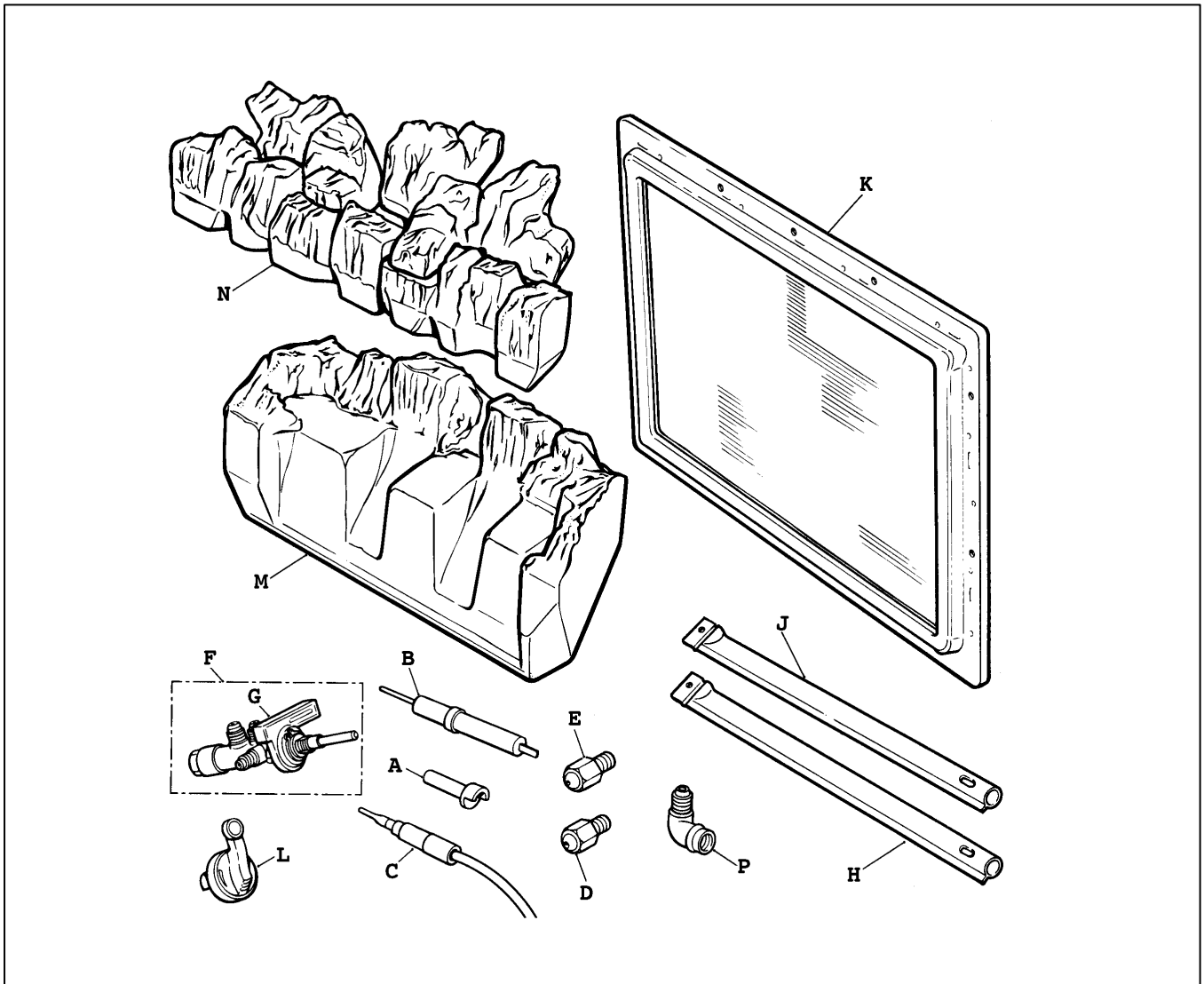

| Key | Description   | No. Off | Part No. |
|-----|---|---------|----------|
| A   | Pilot Injector SIT Ref 0.977.113 (Stamped '27')       | 1       | 524949   |
| B   | Electrode Pin SIT Ref. 0.007.243                      | 1       | 524979   |
| C   | Thermocouple SIT Ref. 0.290.198                       | 1       | 524999   |
| D   | Main Burner Injector Bray Cat 960/240                 | 1       | 551079   |
| E   | Decorative Burner Injector Bray Cat 960/130           | 1       | 525059   |
| F   | Gas Tap & Piezo Unit Copreci 21400/88                 | 1       | 525069   |
| G   | Piezo Generator - Copreci 18600 Twin Spark 250mm Lead | 1       | 525339   |
| H   | Main Burner   | 1       | 525119   |
| J   | Decorative Flame Burner                               | 1       | 525129   |
| K   | Window Unit   | 1       | 525159   |
| L   | Control Knob  | 1       | 525199   |
| M   | Coal Bed Base   | 1       | 525259   |
| N   | Coals - Set of 4                                      | 1       | 525269   |
| P   | Inlet elbow   | 1       | 532519   |

### **Safety First.**

Valor fires are CE Approved and designed to meet the appropriate British Standards and Safety Marks.



### **Quality and Excellence.**

#### **At the heart of every Valor fire.**

All Valor fires are manufactured to the highest standards of quality and excellence and are manufactured under a BS EN ISO 9001 quality system accepted by the British Standards Institute.



### **The Highest Standards**

Valor is a member of the Society of British Gas Industries which works to ensure high standards of safety, quality and performance.



### **Careful Installation**

Valor is a Corgi registered company. All our gas fires must be installed by a competent Corgi Registered Installer in accordance with our Installer Guide and should not be fitted directly on to a carpet or floor of combustible material.



Valor Heating, Erdington, Birmingham B24 9QP

Because our policy is one of constant development and improvement, details may vary slightly from those given in this publication