

users guide

Classic

Your Ideal users guide

See reverse for **Classic** installation & servicing instructions

**SE9 RS, SE12 RS, SE15 RS
& SE18 RS**

When replacing a part on this appliance use only spare parts that you can be assured conform to the safety and performance specification that we require. Do not use reconditioned or copy parts that have not been clearly authorised by Ideal Boilers.

i BOILERS *Ideal*
ENGINEERED FOR PEACE OF MIND

Classic SE RS (Natural Gas Models Only)

Model	GC Appliance No
Classic SE9 RS	41 395 44
Classic SE12 RS	41 395 45
Classic SE15 RS	41 395 46
Classic SE18 RS	41 395 99

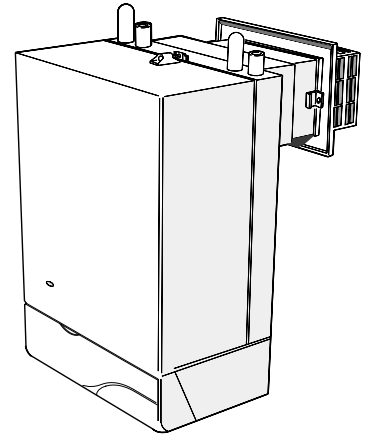

INTRODUCTION

It is essential that the instructions in this booklet are strictly followed, for safe and economic operation of the boiler.

Current Gas Safety (Installation & Use) Regulations or rules in force.

In your own interest, and that of safety, it is the law that this boiler must be installed by a CORGI registered installer or in IE a competent person, in accordance with the above regulations.

Electricity Supply

This appliance must be efficiently earthed.

Supply: 230 V ~ 50 Hz. The fusing should be 3A.

Connection must be made in a way that allows complete isolation of the electrical supply such as a double pole switch having a 3mm (1/8") contact separation in both poles, or a plug and socket, serving only the boiler and system controls. The means of isolation must be accessible to the user after installation.

IMPORTANT NOTES

- This appliance **must not be operated** without the casing correctly fitted and forming an adequate seal.
- If the boiler is installed in a compartment then the compartment **MUST NOT** be used for storage purposes.
- The ventilation provided for the boiler during installation **MUST NOT** be blocked and a check should be made periodically that the ventilation areas are free from any obstruction.
- If it is known or suspected that a fault exists on the boiler then it **MUST NOT** be used until the fault has been corrected by a CORGI registered installer or in IE a competent person.

- Flammable materials must not be placed in close proximity to the appliance. Materials giving off flammable vapours must not be stored in the same room as the appliance.
- Under **NO** circumstances should any of the sealed components on this appliance be used incorrectly or tampered with.

Minimum clearances

A clearance of 533mm (21") **MUST** be available at the front of the boiler for servicing.

The minimum clearances given below **MUST** be complied with in order to maintain the safe running of the boiler .

Above the boiler	100 mm	(4")
At each side of the boiler	5 mm	(1/4")
Underneath the boiler	100 mm	(4")
In front of the boiler	75 mm	(3")

To light the boiler. Refer to Frame 1

If a programmer is fitted, refer to separate instructions for the programmer before continuing.

- CHECK THAT THE ELECTRICITY SUPPLY TO THE BOILER IS OFF.
- Open the controls access door by hinging downwards.
- Ensure that the gas inlet cock (C) is OPEN.
- If an overheat thermostat is fitted press the overheat reset button (D), located as shown in Frame 1.
- Switch ON the electricity supply to the boiler. Check that all external controls, e.g. room thermostat etc., are ON.
- Turn the boiler thermostat knob (B) to position 6. After about 15 seconds the boiler will light automatically - this can be viewed through the sightglass (A).

Set the boiler thermostat to the desired position.
- Close the controls access door.

CAUTION. To avoid the possibility of injury during the installation, servicing or cleaning of this appliance, care should be taken when handling edges of sheet steel components.

1 BOILER CONTROLS

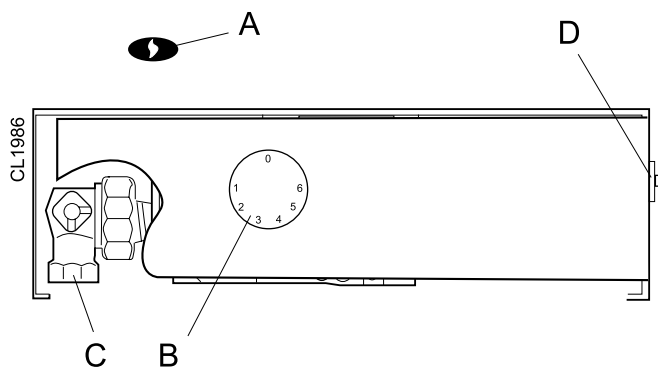

View inside controls area

LEGEND

- A. Sightglass
- B. Thermostat knob
- C. Gas service cock (shown in the OPEN position)
- D. Overheat thermostat reset button (if fitted)

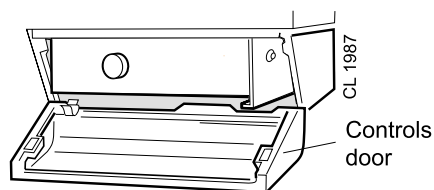

Winter conditions, i.e. central heating and domestic hot water, the thermostat should be set at position 5 or 6.

Summer conditions, i.e. domestic hot water only, the thermostat should be set at position 3.

These settings, however, are offered for general guidance only and other settings may be found preferable, dependent upon the type of system installed or as recommended by the installer.

Approx. flow temperatures for the boiler thermostat settings are:

Knob Setting	Flow Temperature	
	°C	°F
1	56	133
2	61	142
3	66	152
4	72	161
5	77	170
6	82	180

To shut down the boiler

1. For short periods

Turn the boiler thermostat (B) to '0' to turn the boiler OFF. When heating is again required, turn the thermostat knob to the desired heat setting.

2. For longer periods

Turn the boiler thermostat (B) to '0' to turn the boiler OFF. Switch the electricity supply to OFF.

To relight the boiler

Repeat the procedure 1 - 7, detailed in 'To light the boiler'.

Frost protection

If no frost protection is provided and frost is likely during a short absence from home, leave the heating controls at a reduced temperature setting.

For longer periods, the entire system should be drained - including the domestic water supply. If the system includes a frost thermostat then, during cold weather, the boiler should be turned OFF at the time switch(es) ONLY. The mains supply should be left switched ON, with the boiler thermostat left in the normal running position.

All CORGI registered installers carry a CORGI ID card, and have a registration number. Both should be recorded in your **Benchmark** Log Book. You can check your installer by calling CORGI direct on 01563 72300

THE LOG BOOK SHOULD BE COMPLETED AFTER EACH SERVICE AND KEPT WITH THESE INSTRUCTIONS



Boiler overheat thermostat (if fitted)

If the boiler is fitted with a safety 'cutout' thermostat this will shut down the boiler in the event of overheating.

Should this occur allow the boiler to cool, press the reset button (D) then relight as detailed in steps 1-7 in 'To light the boiler'.

If the cutout condition still persists then turn off the boiler and consult a CORGI registered installer or in IE a competent person.

Loss of system water pressure

(Boilers fitted with Classic Sealed System Units only)

If the red arrow on the module pressure gauge is set above zero and the system pressure is seen to fall below this value over a period of time then a water leak is indicated. In this event a CORGI registered installer or in IE a competent person should be consulted.

DO NOT OPERATE THE BOILER IF THE PRESSURE HAS REDUCED TO ZERO FROM THE ORIGINAL SETTING.

Escape of gas

Should a gas leak be suspected, contact your local gas supplier without delay.

Do NOT search for gas leaks with a naked flame.

Cleaning

For normal cleaning simply dust with a dry cloth. To remove stubborn marks and stains, wipe with a damp cloth and finish off with a dry cloth.

Do NOT use abrasive cleaning materials.

Maintenance

The appliance should be serviced at least once a year by a CORGI registered installer or in IE a competent person.



The code of practice for the installation, commissioning & servicing of central heating systems



THIS SYMBOL IS YOUR ASSURANCE OF QUALITY

These appliances are designed for use with Natural Gas only. They have been tested and conform with the provisions of BS. 6332 and BS. 5258.

Caradon Ideal Limited is a member of the Benchmark initiative and fully supports the aims of the programme. Benchmark has been introduced to improve the standards of installation and commissioning of central heating systems in the UK and to encourage the regular servicing of all central heating systems to ensure safety and efficiency.

Natural Gas appliances are service listed by British Gas



CERTIFIED PRODUCT
Manufactured under a BS EN ISO 9001:2000 Quality System accepted by BSI.

Ideal Boilers, P.O. Box 103,
National Ave., Kingston upon
Hull, HU5 4JN. Telephone:
01482 492 251.
Fax: 01482 448 858.
Registration No. London 322 137.

Caradon Ideal Limited
pursues a policy of
continuing improvement in
the design and performance
of its products. The right is
therefore reserved to vary
specification without notice.



i Ideal BOILERS

Caradon
Ideal Limited

Ideal Consumer Helpline Tel: 01482 498 660

www.idealboilers.com