

INSTALLATION COMMISSIONING AND SERVICING INSTRUCTIONS

WALL HUNG RSF GAS FIRED CONDENSING COMBINATION BOILER

GREENSTAR CDi CLASSIC

FOR SEALED CENTRAL HEATING SYSTEMS AND MAINS FED DOMESTIC HOT WATER



The appliances are for use with:
Natural Gas or L.P.G. (Cat. II type C13, C33)

Natural Gas: 29CDi GC number 47-406-34
34CDi GC number 47-406-36
38CDi GC number 47-406-38
42CDi GC number 47-406-10

L.P.G.: 29CDi GC number 47-406-35
34CDi GC number 47-406-37
38CDi GC number 47-406-39
42CDi GC number 47-406-11



CONTENTS

1	KEY TO SYMBOLS	3	6	SERVICING AND SPARES	35
1.1	Key to symbols	3	6.1	Inspection and service	35
1.2	Safety precautions	3	6.1.1	Component access	35
<hr/>			6.1.2	Fan pressure test	36
2	APPLIANCE INFORMATION	5	6.1.3	To Clean the Heat Exchanger	37
2.1	General information	5	6.1.4	To Clean the Burner	37
2.2	Layout & components	6	6.1.5	To Check the Diaphragm in Burner Cover	38
2.3	Technical data	8	6.1.6	To Clean the Condensate Trap	38
<hr/>			6.2	Setting the air/gas ratio	38
3	PRE-INSTALLATION	9	6.3	Replacement of parts	39
3.1	Cleaning primary systems	9	6.4	Short parts list	48
3.2	Mains supply	9	<hr/>		
3.2.1	Electrical supply	9	7	FAULT FINDING & DIAGNOSIS	49
3.2.2	Gas supply	9	7.1	Fault finding	49
3.2.3	Water supply	9	7.2	Central heating function	50
3.3	Water systems and pipe work	10	7.3	Preheat and DHW function	51
3.4	Condensate pipe work	11	7.4	Protection function	52
3.4.1	Internal connections	11	<hr/>		
3.4.2	External connections	12			
3.5	Pressure relief pipe work	13			
3.6	Boiler location & clearances	13			
3.7	Plumbing manifold	15			
3.8	Flue options	16			
3.9	Flue terminal positions	18			
3.10	Plume management terminal positions	19			
<hr/>					
4	INSTALLATION	20			
4.1	Unpacking wall frame and ancillary items	20			
4.2	Wall mounting plate flue opening	21			
4.3	Charging link (filling loop)	22			
4.4	Unpacking the appliance	23			
4.5	Fitting the appliance/boiler connections	24			
4.6	Flue installation	25			
4.6.1	Ø60/100mm Telescopic flue kit:	25			
4.6.2	Ø60mm Plume management kit:	25			
4.6.3	Adjusting the standard terminal length:	25			
4.6.4	Installing the standard flue	26			
4.6.5	Flue terminal plume re-direction:	26			
4.7	Condensate connection	27			
4.8	Electrical	28			
4.9	Position of wired components	29			
<hr/>					
5	COMMISSIONING	30			
5.1	Pre-commissioning checks	30			
5.2	Filling the system	30			
5.3	Starting the appliance	31			
5.4	Water treatment	32			
5.5	Commissioning	32			
5.5.1	Checking the gas inlet pressure	32			
5.5.2	Checking the gas rate	33			
5.5.3	Domestic hot water:	33			
5.5.4	Domestic hot water pre-heat:	33			
5.6	Finishing commissioning	34			

1 KEY TO SYMBOLS

1.1 KEY TO SYMBOLS

WARNINGS

	Warnings in this document are identified by a warning triangle printed against a grey background. Keywords at the start of a warning indicate the type and seriousness of the ensuing risk if measures to prevent the risk are not taken.
--	---

The following keywords are defined and can be used in this document:

- **NOTE** indicates a situation that could result in damage to property or equipment.
- **CAUTION** indicates a situation that could result in minor to medium injury.
- **WARNING** indicates a situation that could result in severe injury or death.
- **DANGER** indicates a situation that will result in severe injury or death.

IMPORTANT INFORMATION

	This symbol indicates important information where there is no risk to people or property.
--	---

ADDITIONAL SYMBOLS

Symbol	Explanation
▶	Step in an action sequence
→	Cross-reference to another part of the document
•	List entry
-	List entry (second level)

SYMBOLS USED IN THIS MANUAL

	Domestic Hot Water
	Central Heating
	Hot Water Storage Cylinder
	Domestic Cold Water Supply
	Electrical Supply
	Gas Supply

Table 1 Commonly used symbols

PLEASE READ THESE INSTRUCTIONS CAREFULLY BEFORE STARTING INSTALLATION.

These instructions are applicable to the Worcester appliance model(s) stated on the front cover of this manual only and must not be used with any other make or model of appliance.

These instructions apply in the UK and Ireland only and must be followed except for any statutory obligations.

This appliance must be installed by a **GAS SAFE** registered, competent person. Failure to install correctly could lead to prosecution.

If you are in any doubt, contact the Worcester Technical helpline (0844 892 3366).

Please leave these instructions with the completed BENCHMARK CHECKLIST, (or a certificate confirming compliance with IS 813, Eire only) and the user manual with the owner or at the gas meter after installation or servicing.

Distance learning and training courses are available from Worcester. The BENCHMARK CHECKLIST can be found in the back of this Installation manual.

∅	Diameter
NG	Natural Gas
LPG	Liquid Petroleum Gas
CH	Central Heating
DHW	Domestic Hot Water
DCW	Domestic Cold Water
PRV	Pressure Relief Valve
NTC	Negative Temperature Coefficient (sensor)
IP	Ingress Protection
RCD	Residual Current Device
TRV	Thermostatic Radiator Valve
ECV	Emergency Control Valve
WRAS	Water Regulations Advisory Scheme
SEDBUK	Seasonal Efficiency of Domestic Boilers in the United Kingdom

Table 2 Abbreviations use in this manual

1.2 SAFETY PRECAUTIONS

IF YOU SMELL GAS:

- ▶ **TURN OFF** THE ECV (EMERGENCY CONTROL VALVE) AT THE METER/REGULATOR
- ▶ **DO NOT** TURN ELECTRICAL SWITCHES ON OR OFF
- ▶ **DO NOT** STRIKE MATCHES OR SMOKE
- ▶ PUT OUT NAKED FLAMES
- ▶ OPEN DOORS AND WINDOWS
- ▶ KEEP PEOPLE AWAY FROM THE AFFECTED AREA
- ▶ **CALL** NATIONAL GAS EMERGENCY SERVICE ON 0800 111 999
- ▶ **LPG BOILERS** CALL THE SUPPLIER'S NUMBER ON THE SIDE OF THE LPG TANK

BOILER OPERATION:

This boiler must only be operated by a responsible adult who has been instructed in, understands, and is aware of the boiler's operating conditions and effects.



Benchmark places responsibilities on both manufacturers and installers. The purpose is to ensure that

customers are provided with the correct equipment for their needs, that it is installed, commissioned and serviced in accordance with the

manufacturer's instructions by competent persons and that it meets the requirements of the appropriate Building Regulations.

The Benchmark Checklist can be used to demonstrate compliance with Building Regulations and should be provided to the customer for future reference.

The guarantee of this product is dependant on the Benchmark checklist being completed and the actions undertaken.

Installers are required to carry out installation, commissioning and servicing work in accordance with the Benchmark Code of Practice which is available from the Heating and Hot water Industry Council who manage and promote the scheme.

Visit centralheating.co.uk for more information.

HEALTH AND SAFETY

The appliance contains no asbestos and no substances have been used in the construction process that contravene the COSHH Regulations (Control of Substances Hazardous to Health Regulations 1988).

COMBUSTION AND CORROSIVE MATERIALS

Do not store or use any combustible materials (paper, thinners, paints etc.) inside or within the vicinity of the appliance.

Chemically aggressive substances can corrode the appliance and invalidate any guarantee.

FITTING AND MODIFICATIONS

Fitting the appliance and any controls to the appliance may only be carried out by a competent engineer in accordance with the current Gas Safety (Installation and Use) Regulations.

Flue systems must not be modified in any way other than as described in the fitting instructions. Any misuse or unauthorised modifications to the appliance, flue or associated components and systems could invalidate the guarantee. The manufacturer accepts no liability arising from any such actions, excluding statutory rights.

SERVICING

Advise the user to have the system serviced annually by a competent, qualified Gas Safe registered engineer. Approved spares must be used to help maintain the economy, safety and reliability of the appliance.

IMPORTANT

The service engineer must complete the Service Record on the Benchmark Checklist after each service.

INSTALLATION REGULATIONS

Current Gas Safety (Installation & Use) Regulations:

All gas appliances must be installed by a competent person in accordance with the above regulations. Failure to install appliances correctly could lead to prosecution.

The appliance must be installed in accordance with, and comply to, the current: Gas Safety Regulations, IEE Regulations, Building Regulations, Building Standards (Scotland) (Consolidation), Building Regulations (Northern Ireland), local water by-laws, Health & Safety Document 635 (The Electricity at Work Regulations 1989) and any other local requirements.

BUILDING REGULATIONS PART L 1A 2010

If the installation is in a new build property or is a first time installation in an existing property, heating systems must conform to current building regulations Part L1a.

All new heating systems in dwellings must have at least two heating zones. Each of these zones will be operated separately by both time and temperature controls.

The exception to this are single storey, open plan dwellings where the living area is more than 70% of the total useable floor area. Then this type of dwelling can be controlled as one zone.

All radiators must have TRVs fitted, where reasonable, in all rooms except bathrooms and rooms with thermostats.

BUILDING REGULATIONS PART L 1B 2010 - BOILER REPLACEMENT

For boiler replacement on an existing system, it is not necessary to zone the system, compliance with the zone requirements can be achieved by a single room thermostat or programmable room thermostat.

BRITISH STANDARDS

Where no specific instruction is given, reference should be made to the relevant British Standard codes of Practice.

BS7074:1 Code of practice for domestic and hot water supply

BS6891 Installation of low pressure gas pipe work up to 35mm (R1½)

BS5546 Installation of gas hot water supplies for domestic purposes

EN12828 Central heating for domestic premises

BS5440:1 Flues and ventilation for gas appliances of rated heating not exceeding 70kW (net) : Flues

BS5440:2 Flues and ventilation for gas appliances of rated heating not exceeding 70kW (net) : Air Supply

BS7593 Treatment of water in domestic hot water central heating systems

BS6798 Installation of gas fired boilers of rated input up to 70kW (net)

Irish Standards

The relevant Irish standards should be followed, including:

- ECTI National rules for electrical installations
- IS 813:2002 for Domestic Gas Installations.

LPG Installations

An appliance using L.P.G. must not be installed in a room or internal space below ground level unless one side of the building is open to the ground.

Timber framed building:

Where the boiler is to be fitted to a timber framed building the guidelines laid down in BS5440: Part 1 and IGE "Gas Installations in Timber Frame Buildings" should be adhered to.

Potable water:

All seals, joints and compounds (including flux and solder) and components used as part of the secondary domestic water system must be approved by WRAS.

CH Water:

Artificially softened water must not be used to fill the central heating system.

BOILER FEATURES

- Pre-wired and pre-plumbed
- Galvanised steel inner frame
- Digital control system
- FX Intelligent controls
- Automatic ignition
- Direct burner ignition electrodes
- Built-in frost protection
- Built-in fault finding diagnostics
- Automatic gas valve
- Modulating combustion air fan with speed regulator
- CH temperature sensor & control
- Pump anti-seizure protection
- Flue gas temperature sensor
- Condensate siphonic trap
- DHW flow sensor & temperature control
- Plate type DHW heat exchanger
- Modulating circulating pump
- Optional cross bonding strip available
 - Part number 7 716 192 686

2 APPLIANCE INFORMATION

2.1 GENERAL INFORMATION

STANDARD PACKAGE:	
A	Wall hung gas fired condensing combi boiler for central heating and domestic hot water
B	Wall mounting plate
C	Hanging bracket
D	Pre-plumbing manifold
E	Hardware pack
F	Charging Link Assembly
G	Literature pack
H	Bottom panel
I	Trap / Siphon Outlet Connection (22 mm Plastic Pipe)

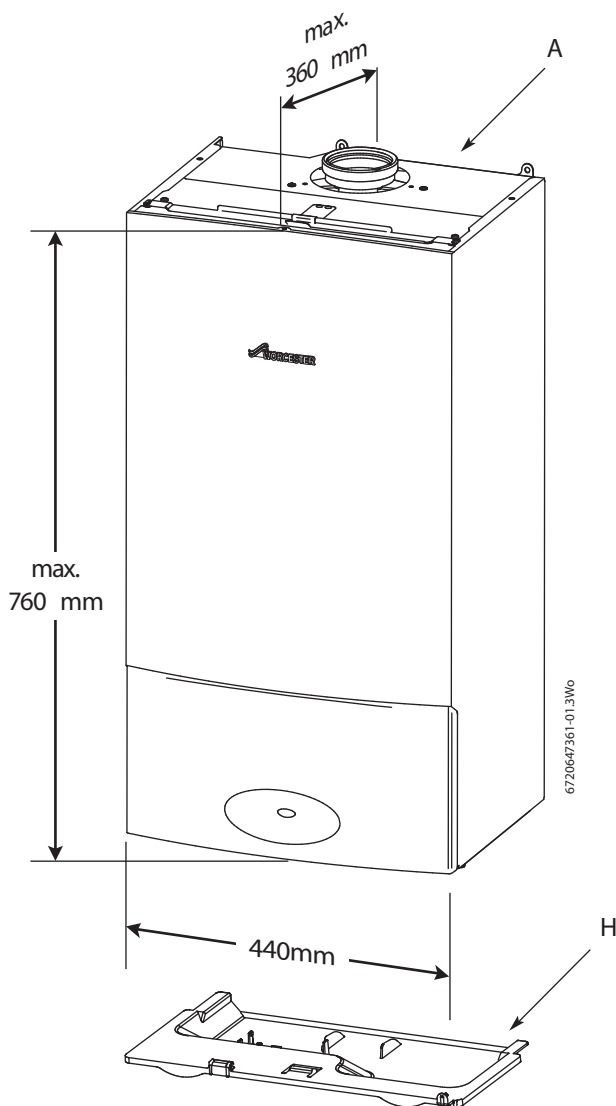

Fig. 1 Overall dimensions

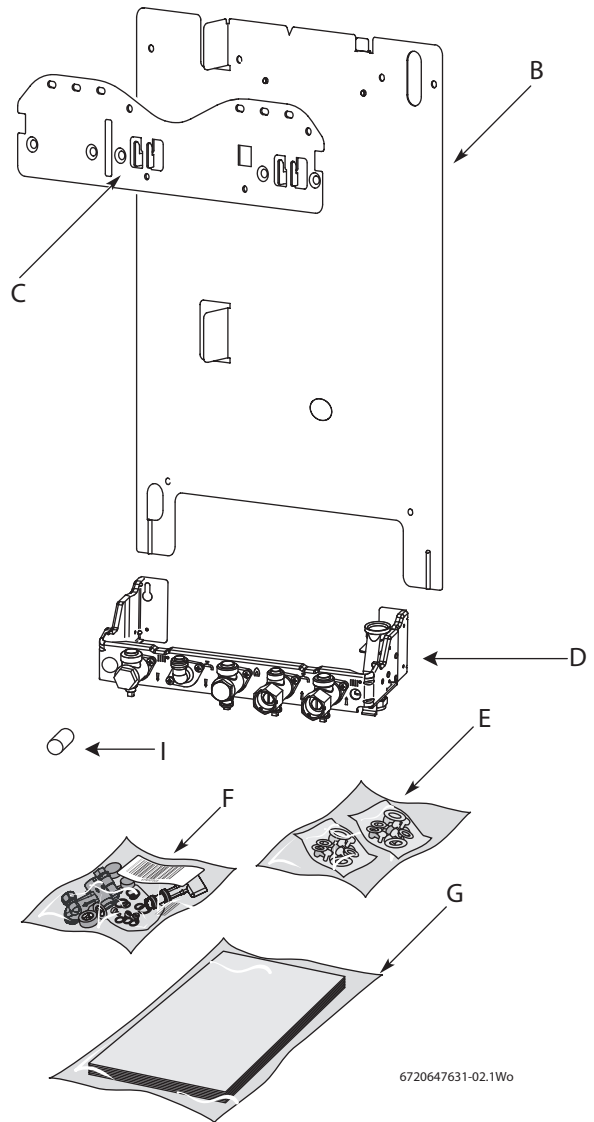
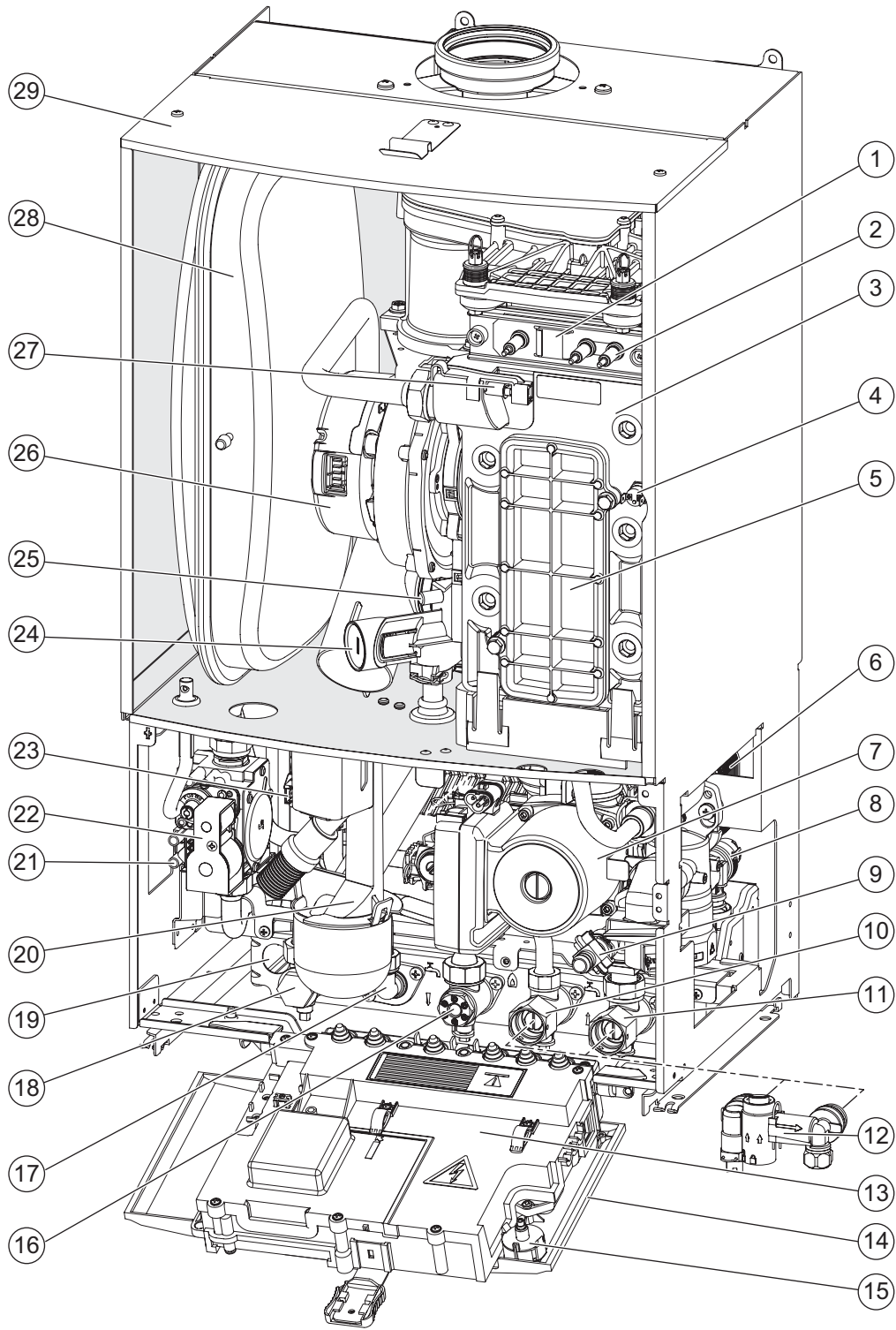

Fig. 2 Standard package

2.2 LAYOUT & COMPONENTS



6720647361-03.1Wc

Fig. 3 Boiler components

The diagram opposite shows the controls in the servicing position and excludes the outer case

1	FLAME VIEWING WINDOW
2	IGNITION ELECTRODES AND FLAME SENSE ELECTRODE
3	HEAT EXCHANGER
4	OVERHEAT THERMOSTAT
5	ACCESS POINT FOR CLEANING HEAT EXCHANGER
6	PLATE TO PLATE DHW HEAT EXCHANGER
7	MODULATING PUMP
8	PRESSURE RELIEF VALVE
9	DRAIN POINT
10	DCW MAINS ISOLATING VALVE
11	CH RETURN ISOLATING VALVE
12	CHARGING LINK ASSEMBLY
13	COVER FOR EXTERNAL WIRING CONNECTIONS
14	CONTROL PANEL IN SERVICE POSITION
15	SYSTEM PRESSURE GAUGE
16	GAS ISOLATING VALVE
17	DHW OUTLET CONNECTION
18	CH FLOW ISOLATING VALVE
19	CONDENSATE DRAIN CONNECTION
20	CONDENSATE SIPHON
21	INLET PRESSURE TEST POINT
22	GAS VALVE
23	DHW TEMPERATURE SENSOR (NTC)
24	AIR / GAS - ADJUST MAXIMUM SETTING SCREW
25	FAN PRESSURE TEST POINT
26	FAN
27	PRIMARY SENSOR
28	EXPANSION VESSEL
29	REMOVABLE TOP CASE PANEL FOR SERVICING

Table 3 Main boiler components

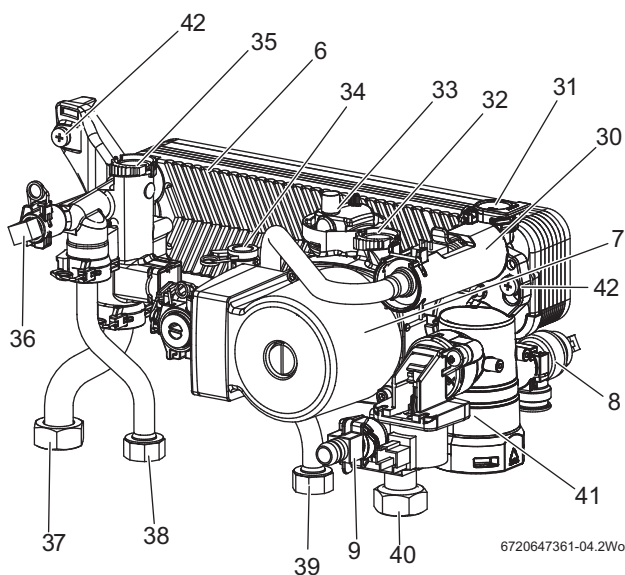

Fig. 4 Hydraulics

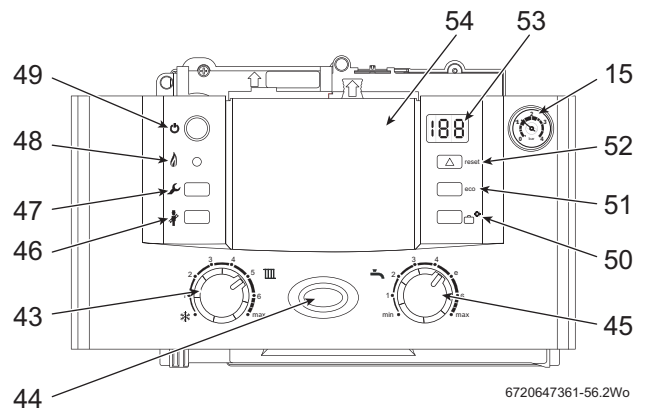

Fig. 5 Control panel

30	FLOW TURBINE
31	UNUSED PORT
32	RETURN CONNECTION TO BOILER HEAT EXCHANGER
33	AUTO AIR VENT
34	EXPANSION VESSEL CONNECTION
35	FLOW CONNECTION FROM BOILER HEAT EXCHANGER
36	DHW SENSOR
37	CH FLOW CONNECTION TO PRE-PLUMBING MANIFOLD
38	DHW OUT CONNECTION TO PRE-PLUMBING MANIFOLD
39	DCW IN CONNECTION FROM PRE-PLUMBING MANIFOLD
40	CH RETURN CONNECTION FROM PRE-PLUMBING MANIFOLD
41	DIVERTER VALVE
42	COMPACT HYDRAULIC MOUNTING SCREW (2) TO BOILER
43	CH TEMPERATURE CONTROL
44	MAINS ON/OFF INDICATOR/DIAGNOSTIC LIGHT (BLUE)
45	DHW TEMPERATURE CONTROL
46	PERFORMANCE TEST BUTTON
47	SERVICE BUTTON
48	BURNER ON INDICATOR LIGHT (GREEN)
49	MASTER SWITCH ON/OFF
50	HOLIDAY BUTTON
51	ECO BUTTON
52	FAULT RESET BUTTON
53	DISPLAY
54	POSITION FOR OPTIONAL PLUG-IN CONTROL

Table 4 Hydraulics and control panel

2.3 TECHNICAL DATA

DESCRIPTION	UNITS	NATURAL GAS				L.P.G			
		29	34	38	42	29	34	38	42
Domestic hot water									
Min. heat input	kW	8.0	8.0	9.8	9.8	11.5	11.5	14.5	14.5
Max. rated heat output	kW	30.9	35.0	40.0	42.0	30.9	35.0	40.0	42.0
Max. rated heat input	kW	30.9	35.0	40.0	42.0	30.9	35.0	40.0	42.0
Max. mains inlet pressure	bar	10	10	10	10	10	10	10	10
Min. mains inlet pressure (working) for max flow	bar	1.4	1.5	1.7	1.9	1.4	1.5	1.7	1.9
Min. mains inlet pressure (working) for operation	bar	0.2	0.2	0.2	0.2	0.2	0.2	0.2	0.2
DHW temperature range	°C	40-60	40-60	40-60	40-60	40-60	40-60	40-60	40-60
DHW specific rate - 30°C rise	l/min	14.8	16.7	19.1	20.1	14.8	16.7	19.1	20.1
Max. DHW flow rate - 40°C rise ± 15%	l/min	11	12	14	15	11	12	14	15
Central Heating									
Max. rated heat input	kW	30.9	30.9	30.9	30.9	30.9	30.9	30.9	30.9
Max. rated heat output net 40/30°C	kW	32.1	32.1	32.1	32.1	32.1	32.1	32.1	32.1
Max. rated heat output net 50/30°C	kW	31.8	31.8	31.8	31.8	31.8	31.8	31.8	31.8
Max. rated heat output net 80/60°C	kW	30.0	30.0	30.0	30.0	30.0	30.0	30.0	30.0
Min. rated heat output net 40/30°C	kW	8.6	8.6	10.6	10.6	8.6	12.4	15.7	15.7
Min. rated heat output net 50/30°C	kW	8.6	8.6	10.5	10.5	8.6	12.3	15.5	15.5
Min. rated heat output net 80/60°C	kW	7.7	7.7	9.4	9.4	7.7	11.0	13.9	13.9
Min. rated heat input net	kW	8.0	8.0	9.8	9.8	8.0	11.5	14.5	14.5
Max. flow temperature (nominal)	°C	90	90	90	90	90	90	90	90
Max. permissible operating pressure	bar	3.0	3.0	3.0	3.0	3.0	3.0	3.0	3.0
Available pump head at 21°C system temp. rise	m	2	2	2	2	2	2	2	2
Gas flow rate - Max. 10 minutes from lighting									
Natural Gas G20	m ³ /h	3.3	3.7	4.2	4.4	-	-	-	-
Propane Gas (LPG)	kg/h	-	-	-	-	2.4	2.7	3.1	3.3
Flue									
Flue Gas Temp. 80/60°C, rated min. load	°C	76/58	81/58	83/58	86/58	76/58	81/58	86/58	87/58
Flue Gas Temp. 40/30°C, rated min. load	°C	55/33	58/33	65/35	66/35	55/33	58/33	65/35	66/35
CO ₂ level at max. rated heat output	%	9.6	9.6	9.7	9.7	11.5	11.5	11.5	11.5
CO ₂ level at min. rated heat output	%	9.0	9.0	9.1	9.1	10.5	10.5	10.5	10.5
NO _x - class		5	5	5	5	5	5	5	5
Condensate									
Max. condensation rate	l/h	2.7	2.7	2.7	2.7	2.7	2.7	2.7	2.7
pH value, approx.		4.8	4.8	4.8	4.8	4.8	4.8	4.8	4.8
Electrical									
Electrical power supply voltage	AC...V	230	230	230	230	230	230	230	230
Frequency	Hz	50	50	50	50	50	50	50	50
Max. power consumption	W	150	160	170	175	150	160	170	175
General Data									
SEDBUK 2005	band	A	A	A	A	A	A	A	A
	%	90.1	90.1	90.1	90.1	90.1	90.1	90.1	90.1
Appliance protection rating	IP	X4D	X4D	X4D	X4D	X4D	X4D	X4D	X4D
Appliance protection rating with mechanical or RF mech. timer fitted	IP	20	20	20	20	20	20	20	20
Permissible ambient temperatures	°C	0-50	0-50	0-50	0-50	0-50	0-50	0-50	0-50
Nominal capacity of appliance	l	3.75	3.75	3.75	3.75	3.75	3.75	3.75	3.75
Noise output level (at DHW inlet pressure 3 bar)	dB(A)	44	44	45	47	44	44	45	47
Total boiler weight (lift weight)	kg	47.5	47.5	47.5	47.5	47.5	47.5	47.5	47.5
Packaged boiler weight	kg	56	56	56	56	56	56	56	56

Table 5 Technical data

3 PRE-INSTALLATION

3.1 CLEANING PRIMARY SYSTEMS

NOTICE:

- ▶ All the following Pre-Installation sections must be read and requirements met before starting boiler or flue installations.

CAUTION:

- ▶ ISOLATE THE MAINS SUPPLIES BEFORE STARTING ANY WORK AND OBSERVE ALL RELEVANT SAFETY PRECAUTIONS.

NOTICE:

- ▶ Debris from the system can damage the boiler and reduce efficiency. Failure to comply with the guidelines for the use of water treatment with the appliance will invalidate the appliance guarantee.

BEFORE CLEANING THE SYSTEM:

- ▶ Ensure that the system and pipe work is in good working order.
- ▶ Where possible keep the existing boiler/circulating pump in place when flushing the system.

FOLLOW THE GUIDANCE OF BS7593:

Treatment of water in domestic hot water central heating and also the flushing guidelines below.

NOTICE: ARTIFICIALLY SOFTENED WATER MUST NOT BE USED TO FILL THE CENTRAL HEATING SYSTEM.

FLUSHING THE SYSTEM

- ▶ Fill the system with cold water and check for leaks.
- ▶ Open all drain cocks and drain the system.
- ▶ Close drain cocks and add a suitable flushing agent **compatible with aluminium** at the correct strength for the system conditions in accordance with the manufacturer's instructions.
The pH value of the system water must be less than 8 or the appliance guarantee will be invalidated.
- ▶ Circulate the flushing agent before the boiler is fired up.
- ▶ Run the boiler/system at normal operating temperature as directed by the manufacturer of the flushing agent.
- ▶ Drain and thoroughly flush the system to remove the flushing agent and debris.
- ▶ It may be necessary to use a power flushing machine to aid the cleansing procedure in some circumstances.
- ▶ Close the drain cocks and refill with fresh water and a suitable inhibitor.
- ▶ Vent any air from the boiler and system.

INHIBITOR

Add a suitable inhibitor or combined inhibitor/anti-freeze, if the system is exposed to freezing conditions, to the heating system in accordance with the DWTA code of practice and manufacturer's guidelines.

WARNING: Sealing agents

- ▶ The addition of sealing agents to the system water is not permitted as this can cause problems with deposits left in the heat exchanger.

WATER TREATMENT

Suitable water treatment products can be obtained from the following manufacturers:

FERNOX Call 0870 601 5000 -or- www.fernox.com

SENTINEL Call 0800 389 4670 -or- www.sentinel-solutions.net

3.2 MAINS SUPPLY

3.2.1 ELECTRICAL SUPPLY

- Supply: 230V - 50 Hz, 140 Watts
- Cable: PVC insulated 0.75 mm² (24 x 0.2 mm) temperature rated to 90°C.
- External 3A fuse to BS1362.
- The appliance must be earthed.
- This appliance must not be connected to a three phase supply.
- IPX4D.

NOTICE: This is reduced to IP20 if the following mechanical timers are fitted;
7 716 192 036 or 7 716 192 037

- Wiring must comply with the latest IEE wiring regulations.

3.2.2 GAS SUPPLY

- Boilers using Natural Gas (NG) must be connected to a governed meter.
- Liquid Petroleum Gas (LPG) must be connected to a regulator.
- Installation and connection of the gas supply to the boiler must be in accordance with BS6891.
- Under no circumstance should the size of the gas supply pipe be less than 22 mm.
- The meter or regulator and pipe work to the meter must be checked, preferably by the gas supplier. This is to ensure that the equipment is in good working order and can meet the gas flow and pressure requirements, in addition to the demand from any other appliance being served.

3.2.3 WATER SUPPLY

WATER MAINS PRESSURE:

- Minimum mains water pressure: 1.5 up to 2.5 bar for maximum performance.
- Maximum mains fed water pressure 10 bar. If necessary fit a pressure reducing valve.

NOTICE: Non return, back flow prevention devices (including those associated with water meters) fitted to the mains water supply can cause a pressure build up which could damage the boiler and other household appliances.

- Where the mains water supply has a non-return, back flow prevention valve fitted, a mini expansion vessel (1) should be connected to the mains water inlet pipe (2) between the non-return valve (3) and the boiler (4) as shown below

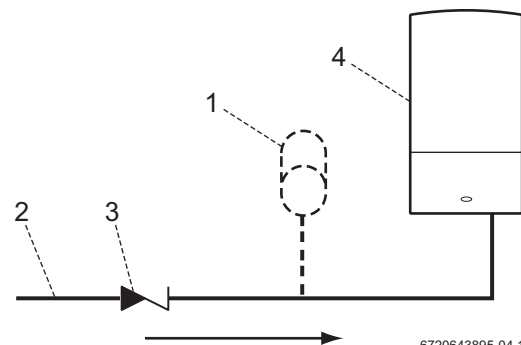

1	Mini expansion vessel
2	Mains water inlet pipe
3	Non return valve
4	Boiler

PRE-INSTALLATION

USE IN HARD WATER AREAS:

Normally there is no need for water treatment to prevent scale formation as the maximum temperature of the HW heat exchanger is limited by the electronic control.

In areas where temporary water hardness exceeds 200 ppm, consideration may need to be given to the fitting of a scale prevention device. In such circumstances, the advice of the local water authority should be sought.

3.3 WATER SYSTEMS AND PIPE WORK

PLASTIC PIPE WORK:

- Any plastic pipe work must have a polymeric barrier with 600mm (minimum) length of copper pipe connected to the boiler.
- Plastic pipe work used for underfloor heating must be correctly controlled with a thermostatic blending valve limiting the temperature of the circuits to approximately 50 °C.

PRIMARY SYSTEMS CONNECTIONS/VALVES:

- All system connections, taps and mixing valves must be capable of sustaining a pressure up to 3 bar.
- Radiator valves should conform to BS2767:10.
- All other valves should conform to BS1010.
- Thermostatic radiator valves (TRV's) must be used on all radiators within the sleeping accommodation but not the radiator where the room thermostat is sited. This must be fitted with lock-shield valves and left open.
- A drain cock is required at the lowest point in the system.
- An air vent is required at all the high points in the system.



An external automatic bypass will need to be installed if a system with two-port motorised valves is installed.

SHOWERS/BIDETS:

- If a shower head can be immersed in water or comes closer than 25mm from the top edge of a bath or shower tray spill over level then an anti-siphon device must be fitted to the shower hose.
- Bidets with direct hot and cold mains water can be used (with the approval of the local water authority) and must be the over rim flushing type with shrouded outlets to prevent the fitting of hand held sprays.

SEALED PRIMARY SYSTEM:



NOTICE: ARTIFICIALLY SOFTENED WATER MUST NOT BE USED TO FILL THE CENTRAL HEATING SYSTEM

- The CH sealed system must be filled using a WRAS approved filling loop or comply with figure 6 for system fill.
- Where the system volume is more than 100 litres or exceeds 2.65 bar at maximum heating temperature, an extra expansion vessel (2) must be fitted as close as possible to the appliance in the central heating return.
- Pressurise the extra expansion vessel (2) to the same figure as the expansion vessel built into the appliance.
- **Do not use galvanised pipes or radiators.**

SYSTEM FILL

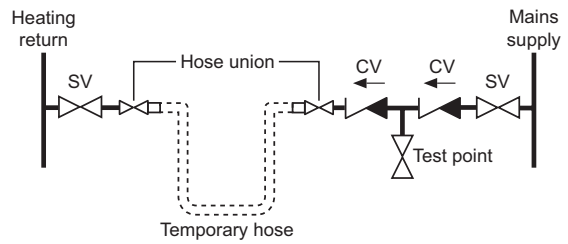

CV = Check Valve
SV = Stop Valve

6720643895-05.1Wo

Fig. 6 System fill

TYPICAL SEALED SYSTEM

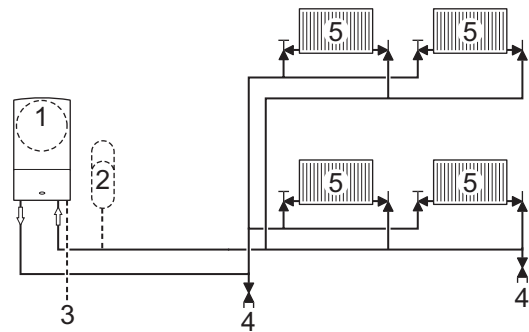

6720643895-06.1Wo

Fig. 7 Sealed system

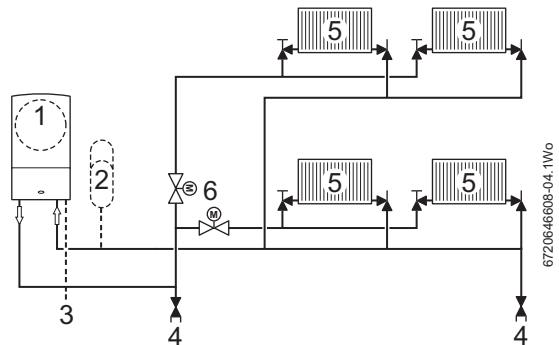

6720646608-04.1Wo

Fig. 8 Sealed system with zone valves

1	Appliance expansion vessel - CH
2	Extra expansion vessel - CH return
3	Pressure relief discharge
4	Drain cock
5	Radiators
6	Zone valves

Table 6 Key to figs. 7 and 8

3.4 CONDENSATE PIPE WORK

	NOTICE:
	▶ Where a new or replacement boiler is being installed, access to an internal “gravity discharge” point should be one of the factors considered in determining boiler location.
	▶ The condensate pipe must be nominally 22mm Ø plastic pipe.
	▶ The condensate pipe work must fall at least 52mm per metre towards the outlet and should take the shortest practicable route.
	▶ Ensure there are no blockages in the pipe run.

Key to condensate illustrations	
1	Condensate discharge from boiler
2	Soil and vent stack
3	Minimum 450mm and up to three storeys
4	Visible air break at plug hole
5	Sink or basin with integrated overflow
6	75mm sink waste trap
7	Condensate pump
*	Condensate trap of 75mm already incorporated into the boiler

3.4.1 INTERNAL CONNECTIONS

In order to minimise risk of freezing during prolonged cold spells, the following methods of installing condensate drainage pipe should be adopted, in order of priority.

Wherever possible, the condensate drainage pipe should be routed and terminated so that the condensate drains away from the boiler under gravity to a suitable internal foul water discharge point such as an internal soil and vent stack. A suitable permanent connection to the foul waste pipe should be used.

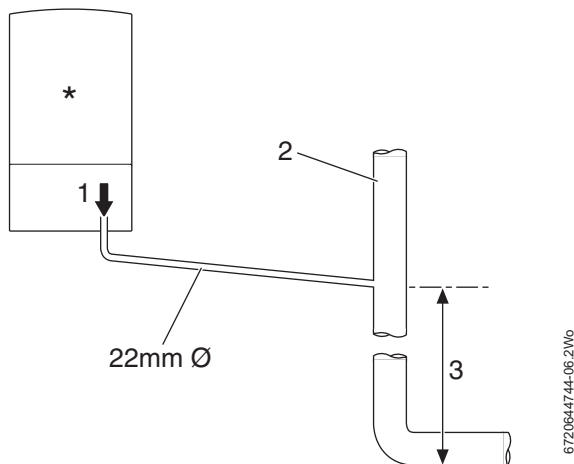

Fig. 9 Disposal to soil vent stack

Alternatively if the first option is not possible an internal kitchen or bathroom waste pipe, washing machine waste pipe etc. can be used. Ensure that the condensate drain pipe is connected “down stream” of the waste trap.

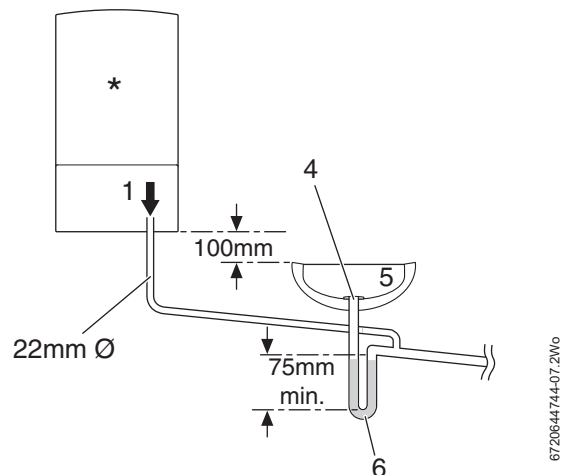

Fig. 10 Disposal to a waste pipe

CONDENSATE PUMP

Where “gravity discharge” to an internal termination is not physically possible, or where very long internal runs would be required to reach a suitable discharge point, condensate should be removed using a proprietary condensate pump, of a specification recommended by the boiler or condensate pump manufacturer.

The pump outlet pipe should discharge to a suitable internal foul water discharge point such as an internal soil and vent stack, internal kitchen or bathroom waste pipe, washing machine waste pipe etc. A suitable permanent connection to the foul waste pipe should be used.

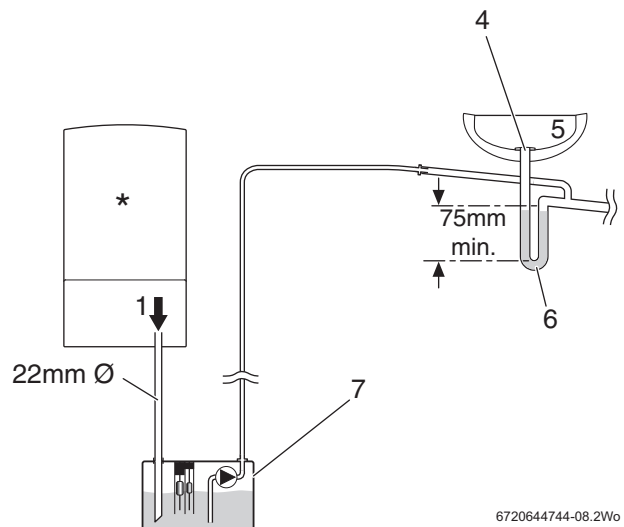

Fig. 11 Condensate pump disposal

3.4.2 EXTERNAL CONNECTIONS

NOTICE: Freezing conditions

- ▶ Pipe work length should be kept to a minimum and the route as vertical as possible.
- ▶ Weather proof insulation must be used.

NOTICE: Condensate waste

- ▶ Care should be taken when siting a soak-away to avoid obstructing existing services.

Continued - Key to condensate illustrations	
8	PVCu strap on fitting
9	100mm Ø minimum plastic pipe
10	Drainage holes
11	Limestone chippings
12	Bottom of sealed tube
13	Insulate and increase pipe size
14	Pipe work transition
15	External air break
16	Air gap
17	External rain water pipe into foul water
18	43mm 90° male/female bend
*	Condensate trap of 75mm already incorporated into the boiler

If no other discharge method is possible then the use of an externally run condensate drainage pipe terminating at a suitable foul water discharge point, or purpose-designed soak away, may be considered. If this method is chosen then the following measures should be adopted:

- ▶ The external run be kept as short as possible and not exceed three metres.
- ▶ The pipe should be run internally as far as possible before going externally and the pipe diameter should be increased to 32mm before it passes through the wall to the exterior. The pipe should be insulated using suitable waterproof and weather resistant insulation.
- ▶ The external pipe should take the shortest and least exposed route to the discharge point, and should "fall" as steeply as possible away from the boiler, with no horizontal runs in which condensate might stand.
- ▶ The use of fittings, elbows etc. should be kept to a minimum and any internal "burrs" on cut pipe work should be removed so that the internal pipe section is as smooth as possible.

FITTING AN EXTERNAL AIR BREAK

- Refer to figure 12 when a rain water down pipe, that goes directly into a sewer that carries both rainwater and foul water, is used to dispose of condensate.
- An air break must be installed in the 43mm pipe work, between the boiler condensate outlet and the drainpipe, outside the property, to avoid flooding during adverse weather conditions.

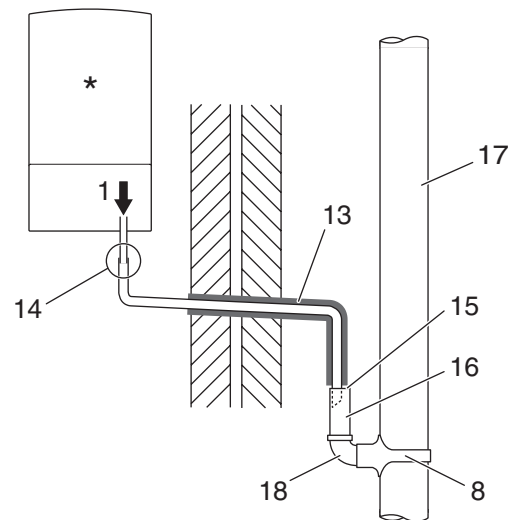

Fig. 12 Disposal into a rainwater down pipe



Condensate drainage pipe can be run above or below ground.

Where the pipe terminates over an open drain or gully, the pipe should terminate below the grating level, but above water level, in order to minimise "wind chill" at the open end.

The use of a drain cover (such as those used to prevent blockage by leaves) may offer further protection from wind chill.

Pipe drainage will be improved if the end is cut at 45° as opposed to a straight cut.

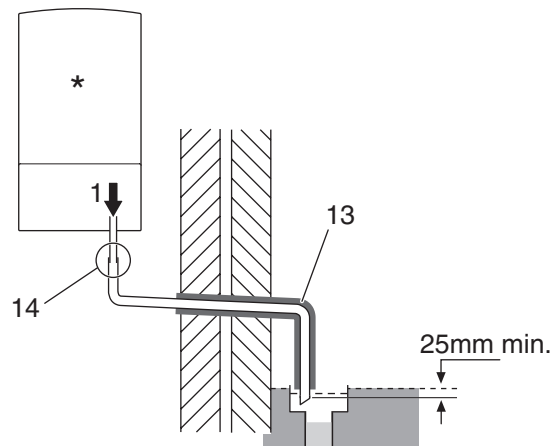

Fig. 13 External disposal

CONDENSATE SOAK AWAY

- The condensate drainage pipe may be run above or below the ground to the soak away. The examples shown on this page run above ground.
- The soak away must use a 100mm Ø plastic tube with two rows of three 12mm holes on 25mm centres and 50mm from the bottom of the tube. The holes must face away from the house.
- The tube must be surrounded by at least 100mm of limestone chippings to a depth of 400mm.



Minimum hole size for the condensate soak away must be 400mm deep by 300mmØ .

In situations where there are likely to be extremes of temperature or exposure, the use of a proprietary trace-heating system for external pipe work, incorporating an external frost thermostat, should be considered. If such a system is used, the requirement to use 32mm pipe does not apply. However, all other guidance above and the instructions for the trace heating system, should be closely followed.

NOTICE: Unheated internal areas.
▶ Internal pipe runs in unheated areas such as lofts, basements and garages should be treated as external runs.

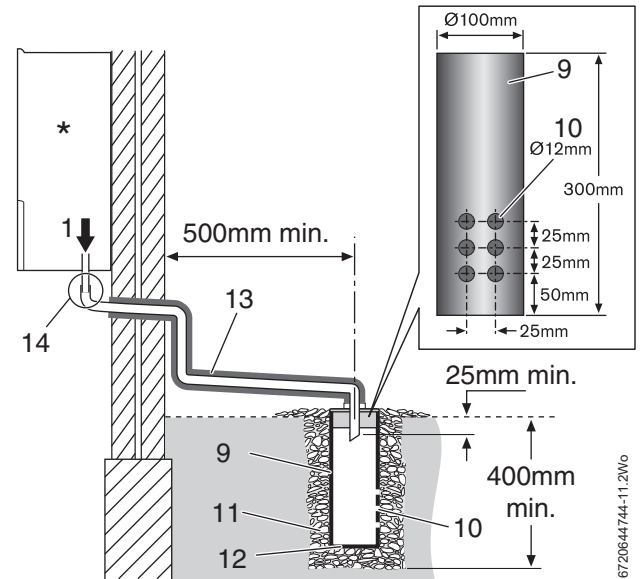

Fig. 14 Soak away

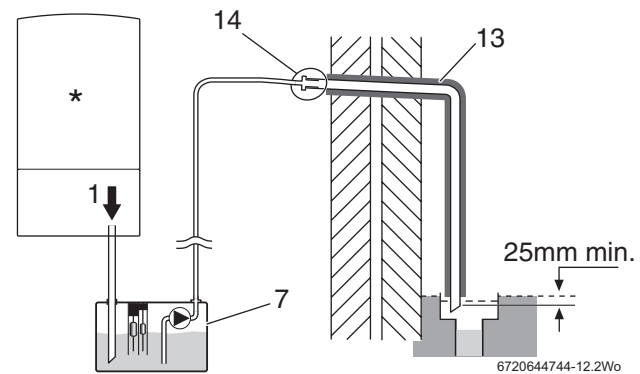

Fig. 15 Condensate pump to external disposal

3.5 PRESSURE RELIEF PIPE WORK

- NOTICE:**
- ▶ The pressure relief valve is a safety device for the boiler and if activated may discharge boiling water or steam through the relief valve drain pipe.
 - ▶ Care should be taken when siting the outlet pipe so that it does not cause an obstruction or discharge above a window, entrance or other public access where it could cause a hazard.

- The pressure relief drain pipe (1) from the boiler should be at least 15mm diameter copper pipe and run downwards, away from any electrical equipment or other hazard, preferably to an external drain or soak away.
- Pipe (1) should be finished with a partial bend, near the outlet to face the external wall (as shown) to help prevent freezing.

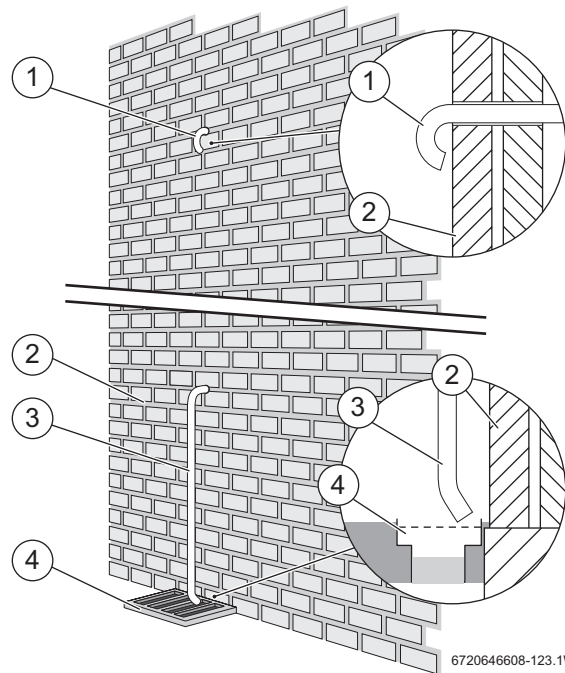

Fig. 16 Pressure relief pipe work

2	Outside wall
1,3	Drain pipe
4	External drain

Table 7 Key to fig 7

3.6 BOILER LOCATION & CLEARANCES

This boiler is only suitable for installing internally within a property at a suitable location onto a fixed, rigid surface at least the same size as the boiler and capable of supporting the boiler weight.

NOTICE:
No surface protection is required against heat transfer from the boiler

COMPARTMENTS:

Follow the requirements of BS6798 and BS5440 Part 2 and note:

- Minimum clearances must be maintained
- An access door is required to install, service and maintain the boiler and any ancillary equipment.
- If an airing cupboard is adapted to house a boiler, then the airing spaces must be separated from the boiler compartment by a non-combustible partition. The partition may be perforated, if required, by holes not exceeding 13 mm in diameter.
- If the appliance is fitted into a cupboard or a compartment is built around the appliance after installation, then the compartment must be built or lined by a non-combustible material.

BOILER CLEARANCES:

The diagram opposite shows the minimum space required to install and service the boiler.

VENTILATION

This is a room sealed appliance and does not require any air for combustion from inside the property.

The requirements of BS 6798 and BS 5440 regarding ventilation do not apply, with the Greenstar CDi Combi boiler. There is no need for ventilation openings to be provided in the compartment because of the low heat loss from the appliance casing, if the clearances shown are maintained.

Do not operate the appliance if the flue terminal fitted on the outside wall or roof is obstructed or damaged.

SERVICING CLEARANCES

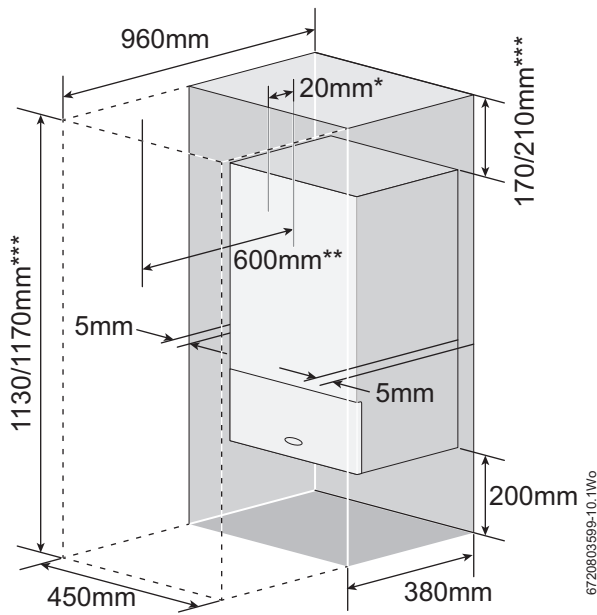

*	Minimum clearance to removable door
**	Minimum clearance required for servicing
***	Height for either 60/100 flue or 80/125 flue

Table 8 Minimum clearances

COMPARTMENTS

Follow the requirements of BS6798 and BS5440 Part 2 and note:

- Minimum clearances must be maintained.
- An access door is required to install, service and maintain the boiler and any ancillary equipment.
- If fitting the boiler into an airing cupboard use a non-combustible material to separate the boiler from the airing space. The material can be perforated up to a maximum hole size of 13mm.

BATHROOMS:

A boiler fitted with a non-mechanical timer or with no timer can be installed in zone 2 or outside the shaded area .

A boiler with a mechanical timer or RF mechanical timer with room thermostat must only be installed outside the shaded area.

Additional RCD (Residual Current Device) protection may be required. Refer to the latest IEE wiring regulations.

NOTICE: Any switch or appliance control using 230 V mains electricity must not be able to be touched by a person using the bath or shower. Electrical switches, fused spur and socket outlets must not be situated in the bathroom.

BATHROOM INSTALLATIONS

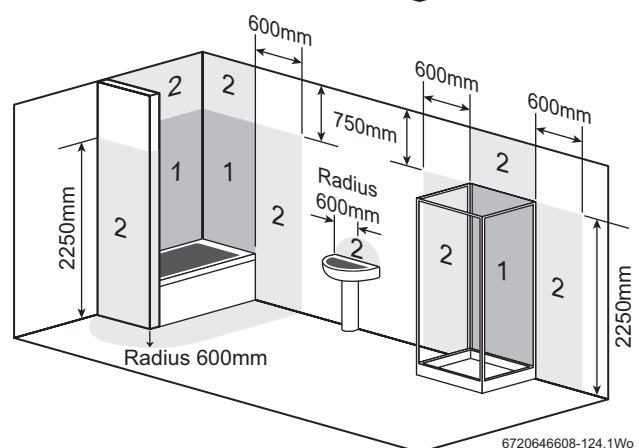
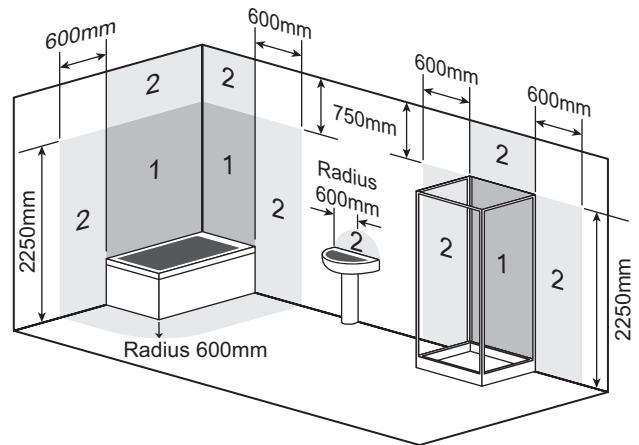

Fig. 17 Bathroom installations

3.7 PLUMBING MANIFOLD

CONNECTIONS:

Heating System: 22mm compression fittings

DHW: 15mm compression fittings

Gas: 22mm compression fittings

Use the fittings supplied in the Hardware pack.

1. CH Flow 22 mm
2. DHW Out 15 mm
3. Mains Gas Supply 22 mm
4. Mains Water In 15 mm
5. CH Return 22 mm

PRE-PLUMBING

With the plumbing manifold installed, pipe work can be installed to the valves on the manifold.

The pipes can be run below the boiler or alternatively up behind the boiler.

RUNNING PIPES BEHIND THE BOILER

If the boiler pipes are to be run behind the appliance ensure that the pipes pass close to the wall as shown in the diagram opposite, and within the pipe guide.

Alternatively a pre-formed pipe kit can be purchased:
part number 7 716 192 607

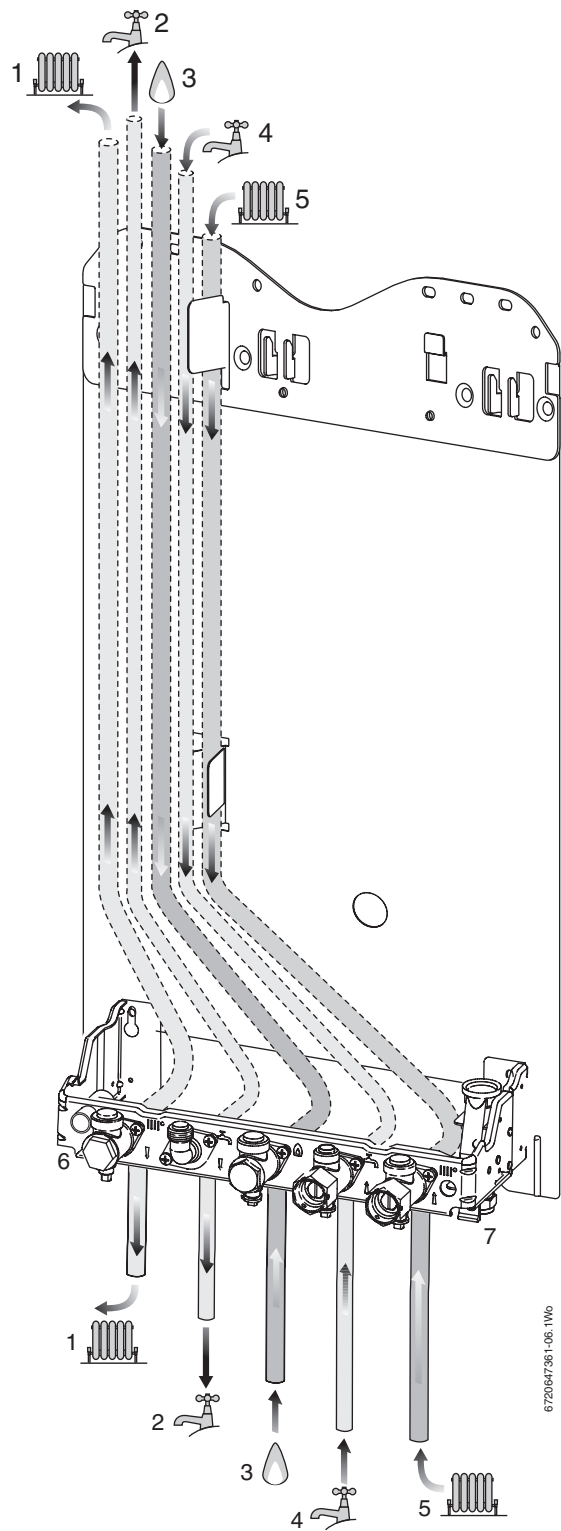

Fig. 18 Plumbing manifold

#	Function	Pipe Ø
1	CH flow	22mm
2	DHW out	15mm
3	Gas	22mm
4	DCW in	15mm
5	CH Return	22mm
6	Condensate	22mm
7	Pressure relief valve	15mm

Table 9

3.8 FLUE OPTIONS

The Greenstar CDi has the option of three horizontal RSF (60/100 telescopic, 60/100 longer telescopic and 80/125 telescopic) flue system and two vertical RSF (60/100 or 80/125) regular flue systems:

The systems have different maximum flue lengths

Maximum horizontal flue lengths (L)		
Boiler model	100mmØ	125mmØ
29CDi	7,000mm	16,000mm
34CDi	7,000mm	16,000mm
38CDi	6,500mm	17,200mm
42CDi	6,000mm	12,500mm

Maximum vertical flue lengths (L)		
Boiler model	100mmØ	125mmØ
29CDi	8,000mm	16,000mm
34CDi	8,000mm	16,000mm
38CDi	8,000mm	18,400mm
42CDi	7,500mm	16,000mm

This page and the next page show various flue options with the maximum straight flue lengths required to achieve the maximum flue length.

	NOTICE: 60/100 Flue systems:
	▶ Each 90° bend used is equivalent to 1.5 metres of straight flue.
	▶ Each 45° bend used is equivalent to 0.75 metres of straight flue.

	NOTICE: 80/125 flue systems:
	▶ Each 90° bend used is equivalent to 2 metres of straight flue.
	▶ Each 45° bend used is equivalent to 1 metre of straight flue.

Telescopic horizontal flue		
Flue option 1	100mmØ	125mmØ
29CDi	570mm	600mm
34CDi	570mm	600mm
38CDi	570mm	600mm
42CDi	570mm	600mm

Horizontal extended flue		
Flue option 2	100mmØ	125mmØ
29CDi	7,000mm	16,000mm
34CDi	7,000mm	16,000mm
38CDi	6,500mm	17,200mm
42CDi	6,000mm	12,500mm

Horizontal extended flue with 1x90° bends		
Flue option 3	100mmØ	125mmØ
29CDi	5,500mm	14,000mm
34CDi	5,500mm	14,000mm
38CDi	5,000mm	15,200mm
42CDi	4,500mm	10,500mm

Horizontal extended flue with 2x90° bends		
Flue option 4	100mmØ	125mmØ
29CDi	4,000mm	12,000mm
34CDi	4,000mm	12,000mm
38CDi	3,500mm	13,200mm
42CDi	3,000mm	8,500mm

High level horizontal extended flue		
Flue option 5	100mmØ	125mmØ
29CDi	7,000mm	16,000mm
34CDi	7,000mm	16,000mm
38CDi	6,500mm	17,200mm
42CDi	6,000mm	12,500mm

High level horiz. extended flue with 2x90° bends		
Flue option 6	100mmØ	125mmØ
29CDi	4,000mm	12,000mm
34CDi	4,000mm	12,000mm
38CDi	3,500mm	13,200mm
42CDi	3,000mm	8,500mm

High level horiz. extended flue with 3x90° bends		
Flue option 7	100mmØ	125mmØ
29CDi	2,500mm	10,000mm
34CDi	2,500mm	10,000mm
38CDi	2,000mm	11,200mm
42CDi	1,500mm	6,500mm

Vertical balanced flue assembly		
Flue option 8	100mmØ	125mmØ
29CDi	8,000mm	16,000mm
34CDi	8,000mm	16,000mm
38CDi	8,000mm	18,400mm
42CDi	7,500mm	16,000mm

Vertical balanced flue with 2x90° bends		
Flue option 9	100mmØ	125mmØ
29CDi	5,000mm	12,000mm
34CDi	5,000mm	12,000mm
38CDi	5,000mm	14,400mm
42CDi	4,500mm	12,000mm

Vertical balanced flue system with 2x45° bends		
Flue option 10	100mmØ	125mmØ
29CDi	6,500mm	14,000mm
34CDi	6,500mm	14,000mm
38CDi	6,500mm	16,400mm
42CDi	6,000mm	14,000mm

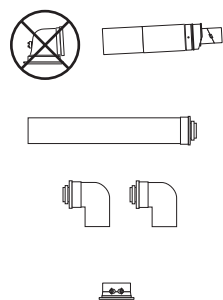
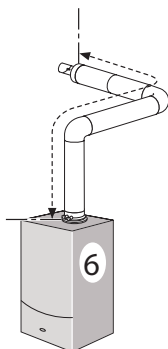
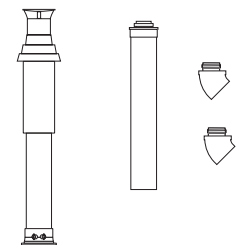
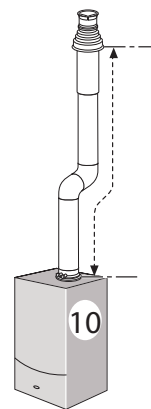
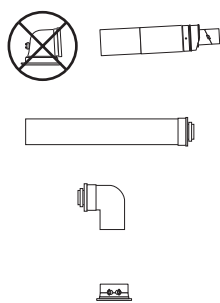
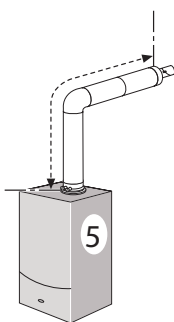
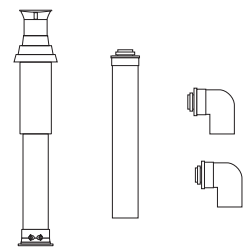
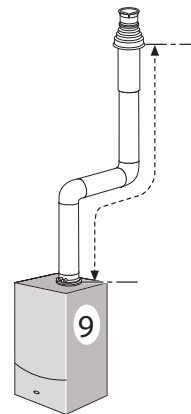
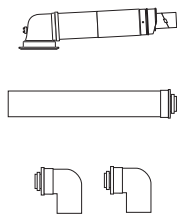
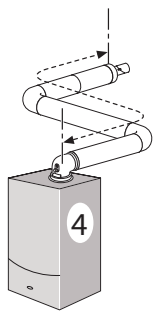
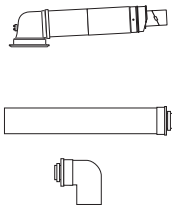
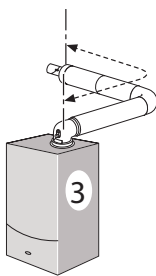
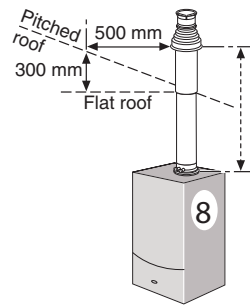
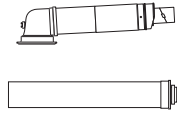
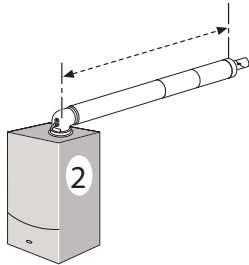
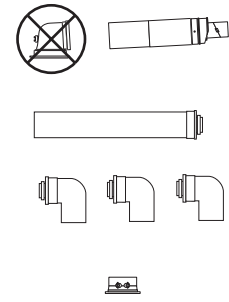
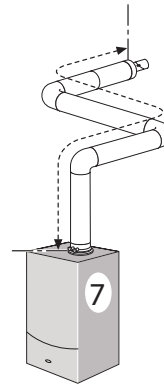
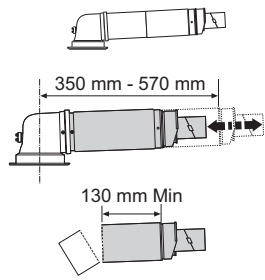
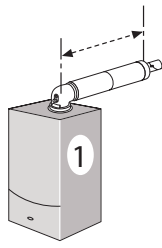

6720643895-12.1Wo

3.9 FLUE TERMINAL POSITIONS

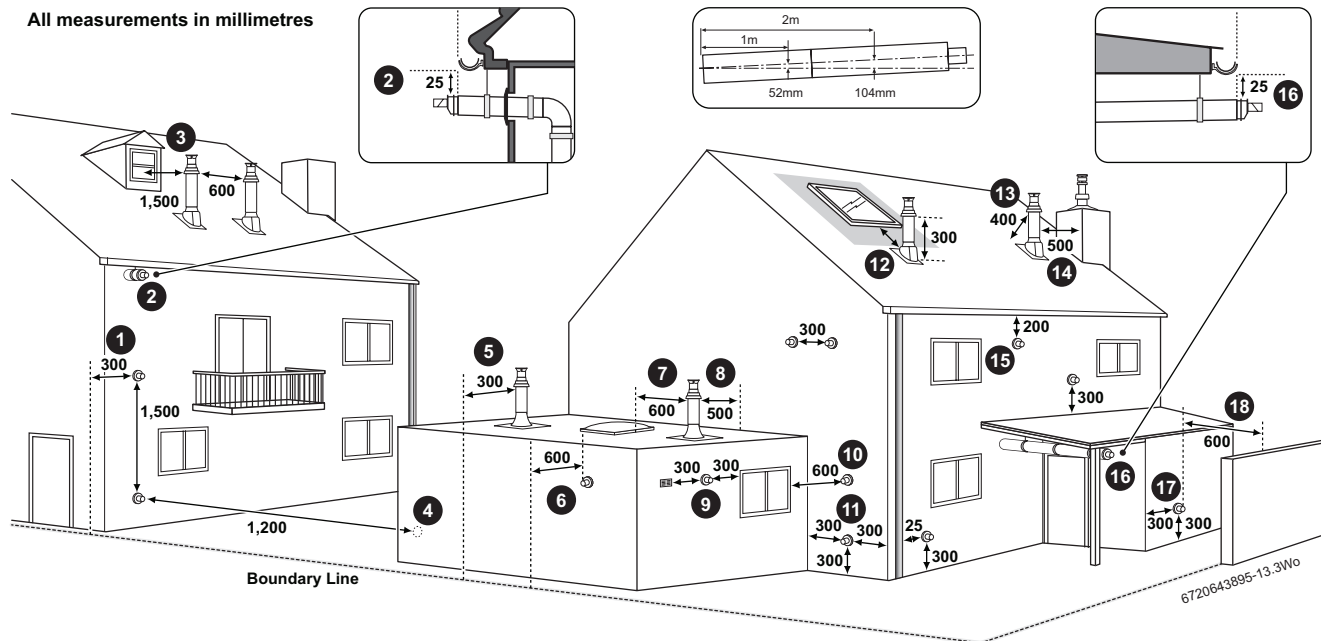

Fig. 19 Flue terminal positions

NOTICE:

- ▶ All measurements are the minimum clearances required.
- ▶ Terminals must be positioned so to avoid combustion products entering the building.
- ▶ Support the flue at approximately one metre intervals and at a change of direction, use suitable brackets and fittings (flue brackets 100mm x 6 part number: 7 716 191 173, flue bracket 125mm part number: 7 716 191 174).

Key to illustration

1. 300mm adjacent to a boundary line.
2. The dimension below eaves, balconies and car ports can be reduced to 25mm, as long as the flue terminal is extended to clear any overhang. External flue joints must be sealed with suitable silicon sealant.
3. 1,500mm between a vertical flue terminal and a window or dormer window.
4. 1,200mm between terminals facing each other.
5. Vertical flue clearance, 300mm adjacent to a boundary line.
6. 600mm distance to a boundary line, unless it will cause a nuisance. BS 5440: Part 1 recommends that care is taken when siting terminal in relation to boundary lines.
7. 600mm minimum clearance from a skylight to a vertical flue.
8. Vertical flue clearance, 500mm to non-combustible building material, and 1,500mm clearance to combustible building material.
9. 300mm above, below and either side of an opening door, air vent or opening window.
10. 600mm diagonally to an opening door, air vent or opening window.
11. 300mm to an internal or external corner.
12. 2,000mm below a Velux window, 600mm above or to either side of the Velux window.
13. 400mm from a pitched roof or 500mm in regions with heavy snow fall.
14. 500mm clearance to any vertical structure on a roof, 600mm to room sealed flue or 1,500 to an open flue.
15. 200mm below eaves and 75mm below gutters, pipe and drains.
16. The dimension below eaves, balconies and car ports can be reduced to 25mm, as long as the flue terminal is extended to clear any overhang. External flue joints must be sealed with suitable silicon sealant.
17. Flue clearance must be at least 300mm from the ground. Terminal guards must be fitted if the flue is less than 2 metres from the ground or if a person could come into contact with the flue terminal.
18. 600mm distance to a surface facing a terminal, unless it will cause a nuisance. BS 5440: Part 1 recommends that care is taken when siting terminals in relation to surfaces facing a terminal.



Note:

- ▶ Installations in car ports are not recommended.
- ▶ The flue cannot be lower than 1,000mm from the top of a light well due to the build up of combustion products.
- ▶ Dimensions from a flue terminal to a fanned air inlet to be determined by the ventilation equipment manufacturer.

3.10 PLUME MANAGEMENT TERMINAL POSITIONS

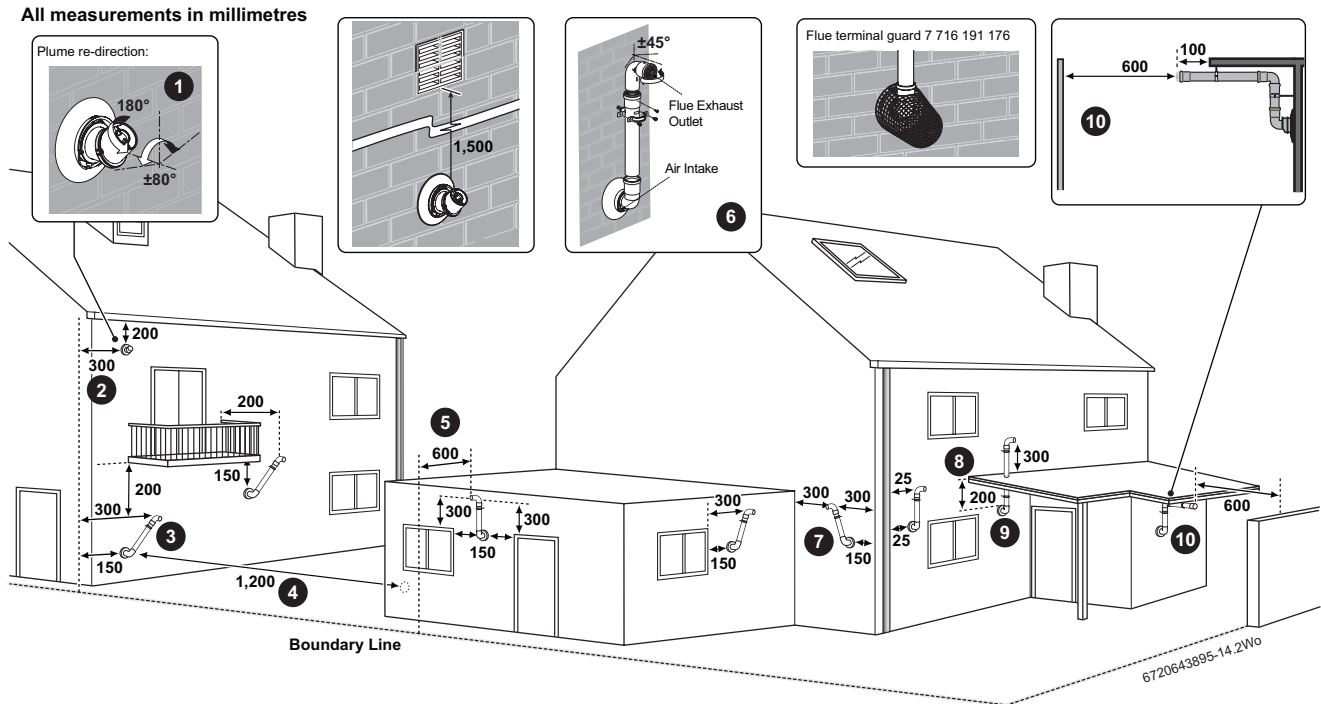

Fig. 20 Plume terminal positions

NOTICE:

- ▶ All measurements are the minimum clearances required.
- ▶ Refer to previous page for all concentric flue terminal positions unless the flue position is specified on the figure above “Plume terminal positions”.
- ▶ Terminals must be positioned so to avoid combustion products entering the building.
- ▶ Support the flue at approximately one metre intervals and at a change of direction, use suitable brackets and fittings.

Key to illustration

1. This feature allows some basic plume re-direction options on a standard telescopic horizontal flue terminal. 300mm minimum clearances to an opening e.g. window. However the minimum clearances to an opening in the direction that the plume management is facing, must be increased to 1,500mm. Where the flue is less than 150mm to a drainpipe and plume re-direction is used the deflector should not be directed towards the drainpipe.
2. 300mm adjacent to a boundary line.
3. Plume Management kit air intake can be reduced to 150mm providing the flue exhaust outlet is no less than 300mm adjacent to a boundary line.
4. 1,200mm between terminals facing each other.
5. 600mm distance to a boundary line, unless it will cause a nuisance. BS 5440:Part 1 recommends that care is taken when siting terminal in relation to boundary lines.
6. Using a Plume Management kit the air intake measurement can be reduced to 150mm providing the flue exhaust outlet has a 300mm clearance. Plume kits running horizontally must have a 10° fall back to the boiler for proper disposal of condensate. For details on specific lengths see relevant boiler Technical & Specification information.
7. Internal/external corners. The air intake clearance can be reduced to 150mm providing the flue exhaust outlet has a 300mm clearance.
8. Clearances no less than 200mm from the lowest point of the balcony or overhang.
9. 1,200mm from an opening in a car port on the same wall e.g. door or window leading into the dwelling.
10. 600mm distance to a surface facing a terminal, unless it will cause a nuisance. BS 5440: Part 1 recommends that care is taken when siting terminals in relation to surfaces facing a terminal.



Note:

- ▶ Installations in car ports are not recommended.
- ▶ The flue cannot be lower than 1,000mm from the top of a light well due to the build up of combustion products.
- ▶ Dimensions from a flue terminal to a fanned air inlet to be determined by the ventilation equipment manufacturer.

4 INSTALLATION



WARNING: All the previous Pre-Installation sections must be read and requirements met before starting boiler or flue installation.

4.1 UNPACKING WALL FRAME AND ANCILLARY ITEMS LIFTING AND CARRYING PRECAUTIONS:



WARNING:

- ▶ Lift only a manageable weight, or ask for help.
- ▶ When lifting the boiler, bend the knees, and keep the back straight and feet apart.
- ▶ Do not lift and twist at the same time.
- ▶ Lift and carry the boiler close to the body.
- ▶ Wear protective clothing and gloves to protect from any sharp edges.

IMPORTANT HANDLING INSTRUCTIONS

- It is advised that two people are used to carry the carton from the van to the point of delivery.
 - Once the carton has been delivered, the top of the carton is opened.
- If a sharp implement is used make sure the carton is not pierced and that the implement is used in such a way so that it may not cause personal injury. All sharp objects must be covered or the blade retracted after use and put away in a safe place.
1. The upper support is now removed with the components (bottom panel, pre-plumbing manifold, fixings, documentation set, charging link, hanging bracket).
 2. The boiler wall mounting plate can now be pulled out.

Additional requirements for roof space installation:

- The boiler should be first unpacked before ascending ladder to loft space.
- Two sets of steps should be used.
- Two people should share the lifting of the boiler up to the loft hatch, where the boiler is entered into the loft space tilted and slid on its back into the loft.

Once the appliance is removed from its packaging check the contents against the packing list.



NOTICE: Before installing appliance ensure system has been cleaned as explained on page 9.

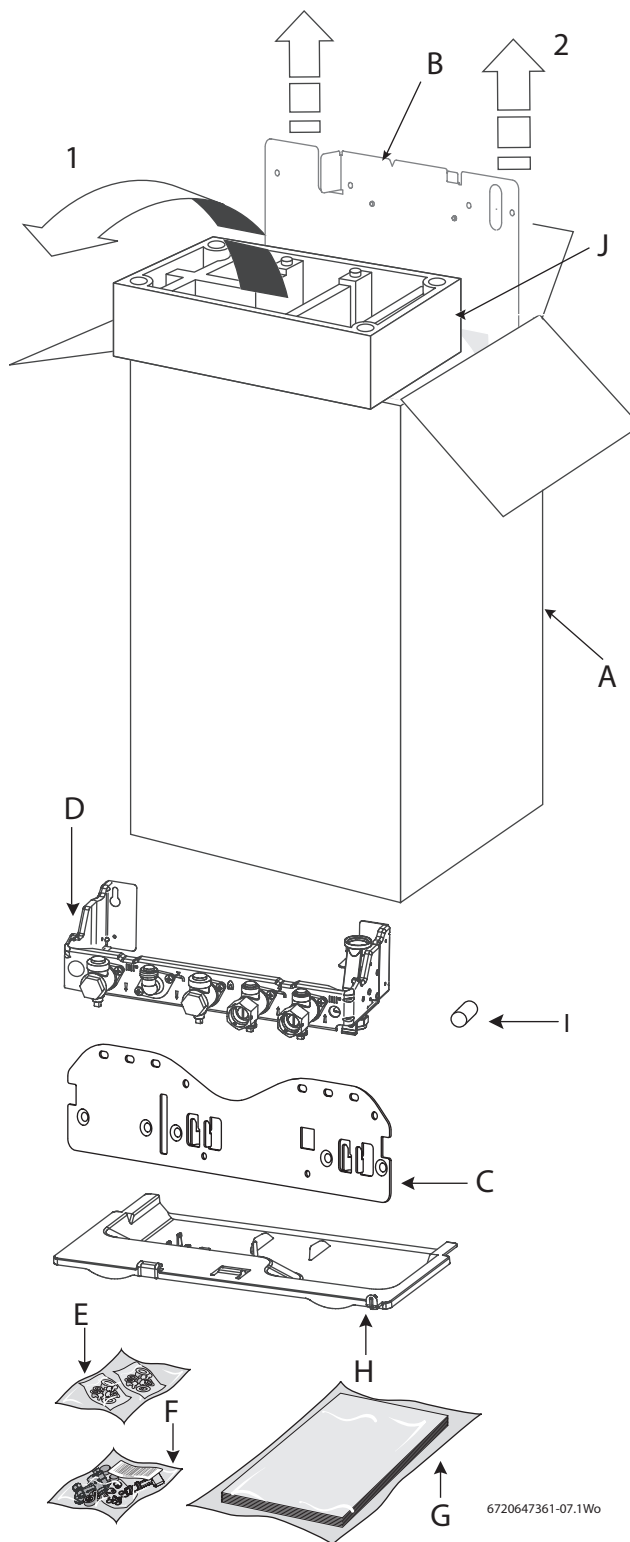

6720647361-07.1Wo

- A - Carton
- B - Wall mounting plate
- C - Hanging bracket
- D - Pre-plumbing manifold
- E - Hardware pack
- F - Charging Link Assembly
- G - Literature pack
- H - Bottom panel
- I - Trap / Siphon Outlet Connection (22mm Plastic Pipe)
- J - Upper support (polystyrene)

4.2 WALL MOUNTING PLATE FLUE OPENING

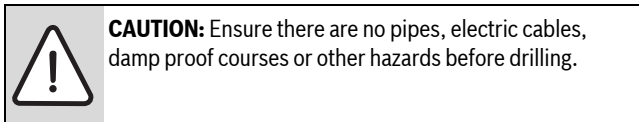

SAFETY:

All relevant safety precautions must be undertaken. Protective clothing, foot wear, gloves and safety goggles must be worn as appropriate.

FIXING THE POSITION OF THE WALL MOUNTING PLATE:

- The diagram opposite shows the relative positions of the flue and the fixing of the wall mounting plate, the hanging bracket and pre-plumbing manifold.
- ▶ Place the hanging bracket on the wall mounting plate.
- ▶ Place the wall mounting plate with hanging bracket against the wall in the desired position.
- ▶ Mark fixing points through at least:
 - one of the holes A
 - one of the holes B
 - hole C
 - hole D
 in the wall mounting plate/hanging bracket.
- ▶ Drill the 4 holes for wall mounting plate, hanging bracket and pre-plumbing manifold.
- ▶ Secure wall mounting plate with hanging bracket with four screws (supplied with the boiler). Do not fully fasten the lower two screws.

FLUE OUTLET

- ▶ Follow the diagram opposite to mark the centre of the flue for rear outlet (1 & 2) or for side outlet (2 & 3).



Increase this height by 52mm for every 1000mm of horizontal length that the flue outlet is away from the boiler.

- ▶ For the 60/100mmØ flue make a 125mm diameter hole through the wall using a core drill or similar.
For flues using an optional weather collar, fitted from inside the building make a 150mmØ hole.
- ▶ Clear away any debris.

FIXING THE PRE-PLUMBING MANIFOLD:

- ▶ Mount the pre-plumbing manifold on the two lower screws and secure the screws.

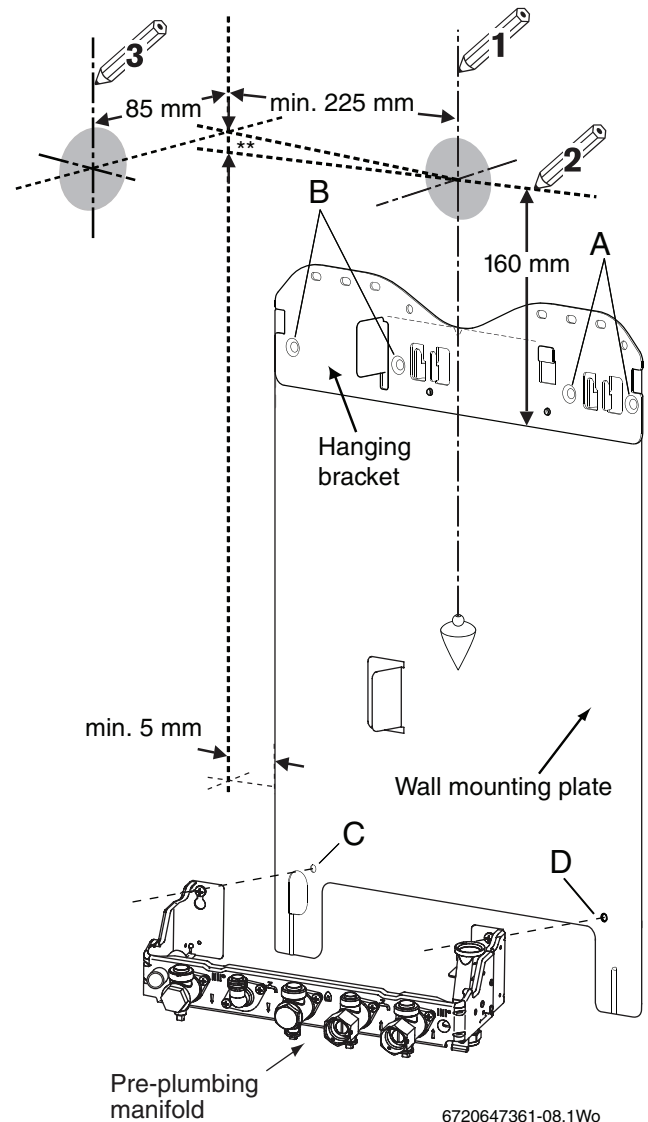

Fig. 21 Wall mounting plate and manifold

4.3 CHARGING LINK (FILLING LOOP)

- ▶ Fully close the isolating valves on both the cold water inlet and CH return connections.
 - ▶ Check that the gas and water connections are tight.
1. Unscrew the blanking plugs from both the cold water inlet and CH return connections.
 - ▶ Place the filter inside the inlet side of the Charging Link ensuring that the filter mesh is inside the inlet.
 - ▶ Fit the Charging Link assembly onto the cold water inlet and CH return connections.
 - ▶ Do not insert the Charging Key at this stage.
 2. Ensure that the Charging Link is pushed in fully to the stop tabs on both sides of the Charging Link.
 - ▶ Fit two M4 screws complete with washers to each of the two connections.

- ▶ Do not attempt to turn the brass hexagon connectors.
- ▶ Ensure that the white plastic control tap on the Charging Link is turned fully into its closed position, see diagram 3.



NOTICE: Only proceed further and fill the boiler and system once the boiler is fitted and all connections are water tight

- ▶ Open the isolating valves on both the cold water inlet and CH return connections.
- ▶ Insert the Charging Key initially aligning the arrow on the key with the “unlock” symbol on the Charging Link body. Ensure that the key is inserted fully and turn to the “lock” position. Check that the key is secure, see diagram 3 below.
- ▶ To fill the system from the cold water inlet turn the white plastic control tap on the Charging Link to the fully out position.
- ▶ Once the system has been filled turn the white Control Tap to its closed position and then remove the Charging Key by turning back to its “unlock” position and withdrawing. Store the Charging Key in the clip provided on the inside of the bottom panel.



It is not possible to access the third screw hole so this can be left.

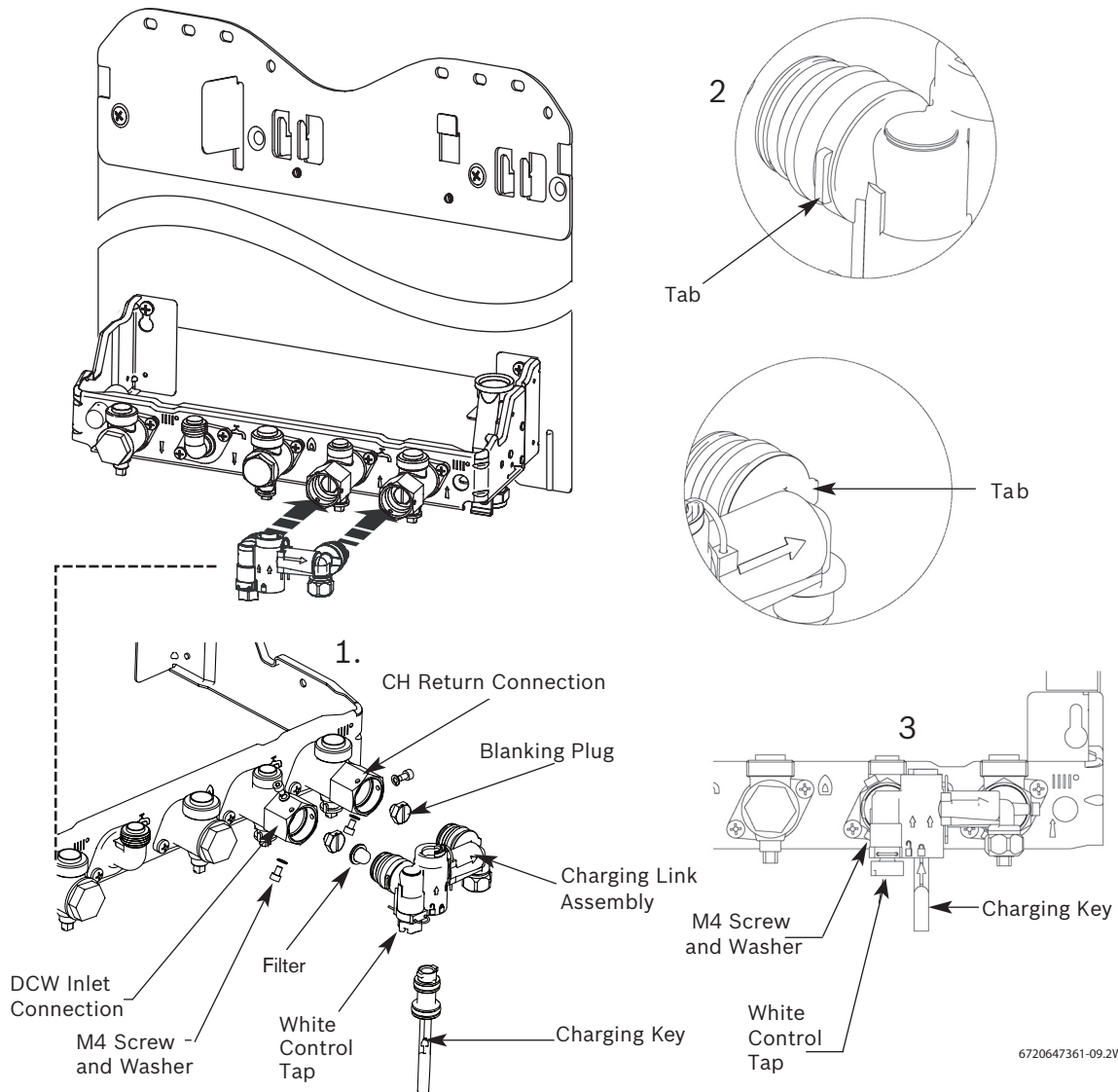

Fig. 22 Fitting the charging link

4.4 UNPACKING THE APPLIANCE

1. With the wall frame and ancillary items removed (see page 22), lay the carton (A) on its back.
2. Open the carton bottom flaps and fold under boiler. Do not remove the packaging base.
3. Stand carton (A) with boiler upright on the packaging base (B).
4. Remove outer carton (A) and place safely away from the working area.
5. Remove the protective wrapping (C).
6. Lie the boiler on its back.
7. Remove the packaging base (B) and place safely away from the working area.

REMOVING OUTER CASE

8. Loosen but do not remove the 2 screws (E) securing boiler casing at the bottom of the appliance.
9. Pull upwards to release the clip (F) on top of the boiler and pull the case upwards.
10. Remove the outer case.
11. Remove the protective packaging (G) from the electrode assembly.

- A - Outer carton
- B - Packaging base
- C - Protective wrapping
- D - Appliance outer case
- E - Screws
- F - Clip
- G - Protective packaging

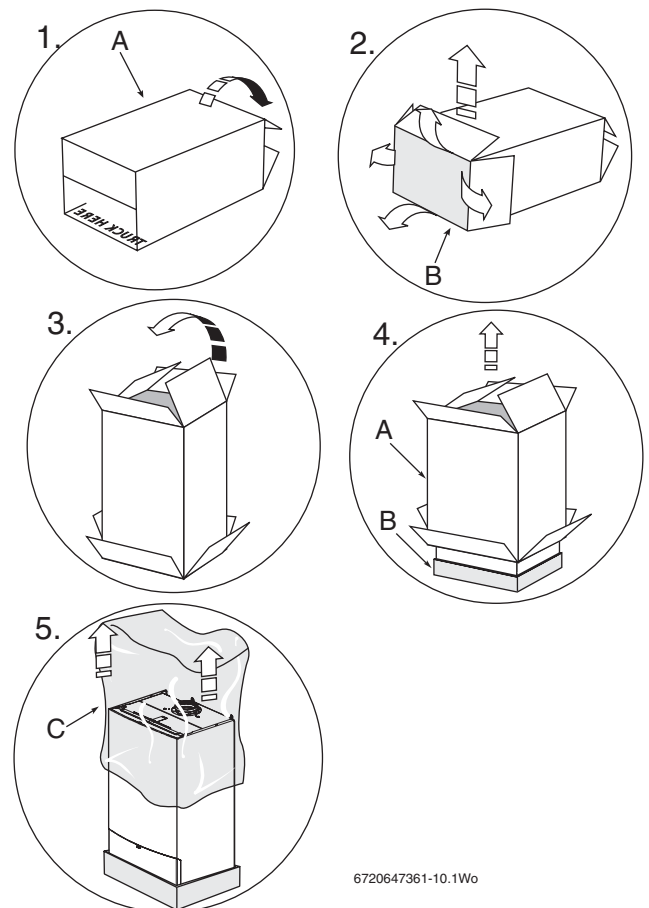

Fig. 23 Removing the packaging

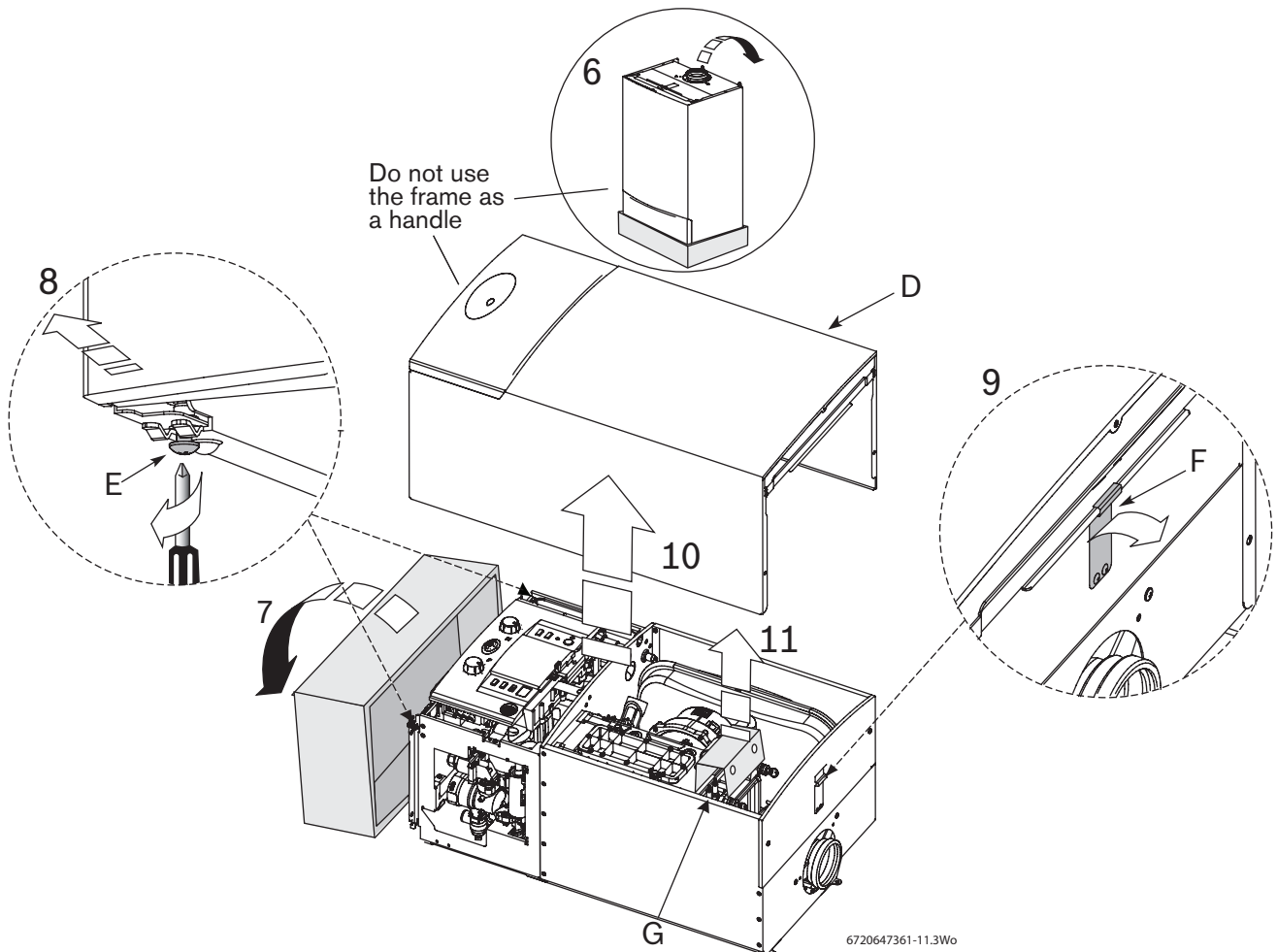



Fig. 24 Unpacking the boiler

4.5 FITTING THE APPLIANCE/BOILER CONNECTIONS

 **CAUTION:** Isolate the mains gas supply before starting any work and observe all relevant safety precautions.

GAS AND WATER CONNECTIONS:

► System pipes may be run vertically upwards behind the boiler or below it. See Plumbing Manifold Section on page 15.

- A - CH flow (22mm),
- B - CH return (22mm),
- C - Gas inlet (22mm),
- D - DHW outlet (15mm),
- E - Cold water inlet (15mm)

- Fit sealing washers to service valves before hanging boiler.
- Remove dust caps from connections on boiler.

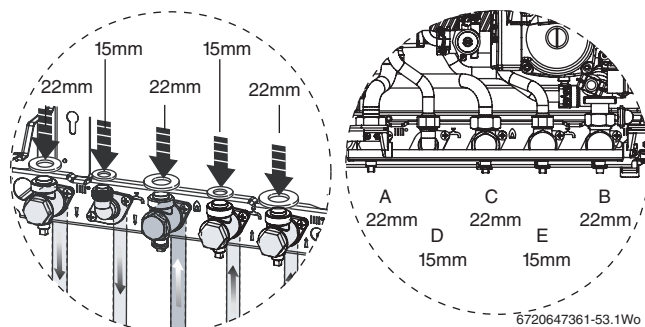

 **NOTICE:** Before hanging the boiler on the wall mounting plate ensure the pressure relief valve connection is in the DOWN position. This is located on the right hand side of the wall frame at the rear.

- The pressure relief connector must be repositioned after the boiler has been correctly mounted to the wall plate. Refer to action step 5.

1. Pull the extended tab/lever forward and down until there is no further travel.
2. Hang the boiler on to the hanging bracket. The lugs pass through the rectangular holes in the boiler back panel. Take care not to disturb the washers on the connections.

 It is recommended the lifting operation is carried out by 2 people, observing all precautions for safe lifting of heavy objects

Do not lift by the top case panel. There are two handling holes incorporated into the inner casing left and right in the lower section of the appliance.

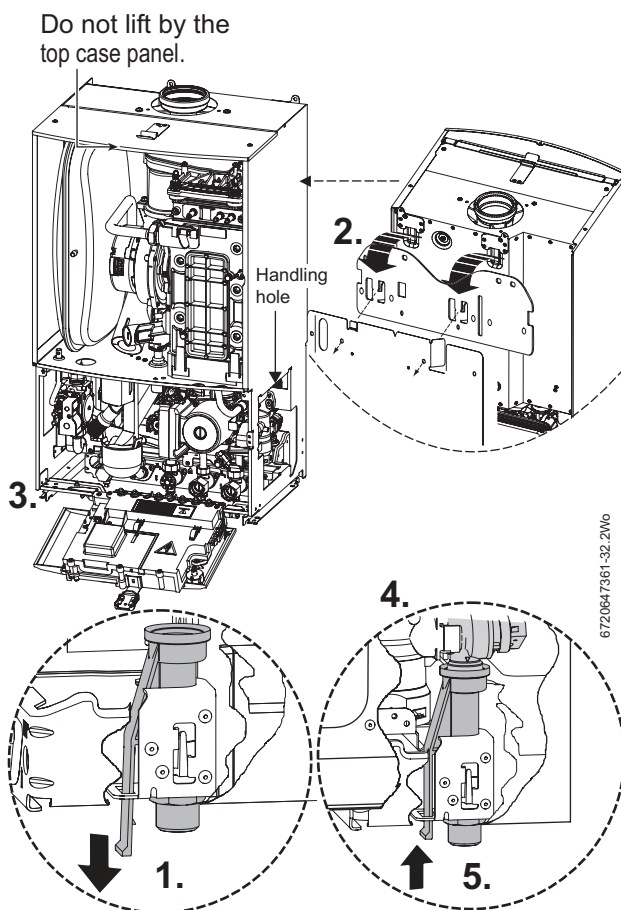

3. Lower the control panel into the service position by pulling the white plastic clip down.
4. Make connections between the boiler and the pre-plumbing manifold and the pre-plumbing manifold and the system pipes.
 - Connect the gas supply to the boiler gas cock 22mm compression.
 - Connect cold water in and DHW out to the boiler's 15mm compression connectors.
 - Connect the CH flow and CH return pipes to the boiler's 22mm compression connections.
 - Connect the condensate discharge pipework to the boiler's condensate outlet connections.
5. Push the lever on the pressure relief connector UP until the stop on the inside of the handle is over the shoulder of the metal bracket to secure in place.

4.6 FLUE INSTALLATION

HORIZONTAL FLUE (60/100mm diameter)

For vertical flues and 80/125mm horizontal flues, please refer to separate Flue Kit instructions.



Apply silicone lubricant to the sealing surfaces of the flue components to ease assembly of flue components.

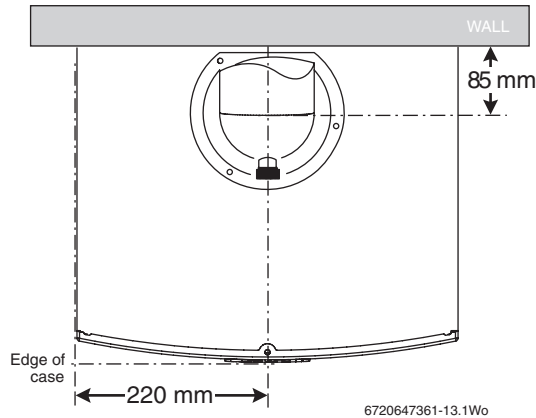

Fig. 25

4.6.1 Ø60/100MM TELESCOPIC FLUE KIT:

Standard telescopic flue 350 - 570mm ,
part Number: 7 716 191 082

Longer Telescopic flue 570 - 790mm,
part number: 7 716 191 171

The standard telescopic flue terminal length can be reduced or extended to within 350 to 570 mm or 570 to 790mm for the longer telescopic flue without cutting and can be used with Condensfit II flue extension components.

The terminal end of the standard telescopic flue can be further reduced to 130mm, if necessary, refer to the Flue Instruction manual supplied.

The plume deflector can be adjusted to redirect the flue discharge allowing some plume management control, alternatively, a complete plume management system can be fitted to the flue terminal.

Refer to the Flue Instruction manual supplied with the flue kit.

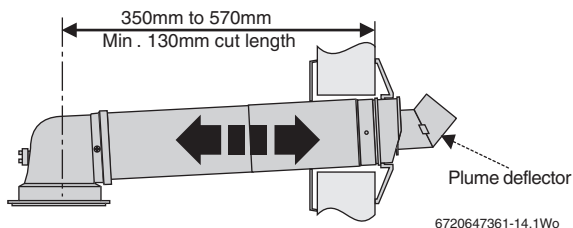

Fig. 26 Telescopic flue

4.6.2 Ø60MM PLUME MANAGEMENT KIT:

Part Number: 7-716-191-086

The plume management system connects to the terminal outlet of the Telescopic flue and must not be used with the flue terminal of the Standard Flue Kit.

The plume management system can be reduced by cutting (min. 500mm) and can be used with plume management extension components.

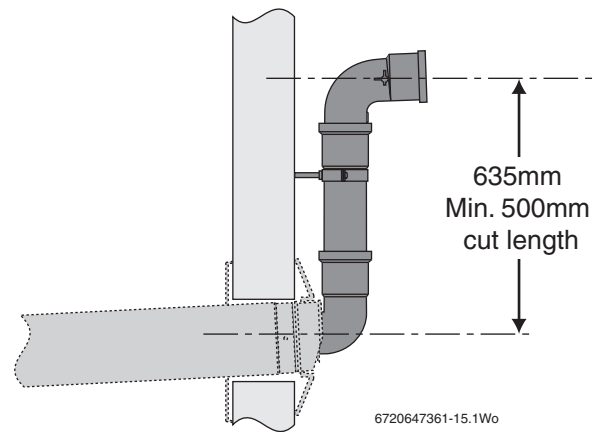

Fig. 27

Ø60mm PLUME MANAGEMENT KIT (7-716-191-086) replaces the plume deflector in the Ø60/100mm telescopic flue terminal.

4.6.3 ADJUSTING THE STANDARD TERMINAL LENGTH:

1. Extend tube (1) by withdrawing from tube (2) to achieve the flue length required, 350 - 570mm for the standard telescopic flue or 570 - 790mm for the longer telescopic flue. Secure with screw provided and seal joint with the aluminium tape supplied.

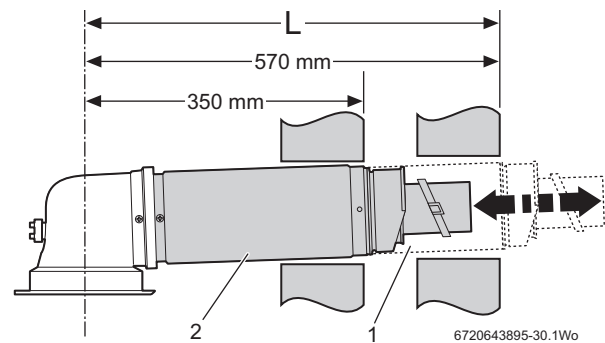

Fig. 28 Standard telescopic flue

Reducing the standard terminal length:

2. Remove securing screws (3) to detach the terminal assembly from the turret. Slide terminal section (2) from the terminal assembly and discard. To use terminal (1) without cutting remove the location lug (4) on the inner flue tube (5) and remove any burrs. To reduce the terminal length further:
3. Mark the length required for the terminal (6) as shown (min. 130mm) and cut square, taking care not to damage the tubes. Remove any burrs and chamfer the outer edge of the tubes to assist ease of connection and prevent seal damage.



The aluminium tape is not required when reducing the terminal.

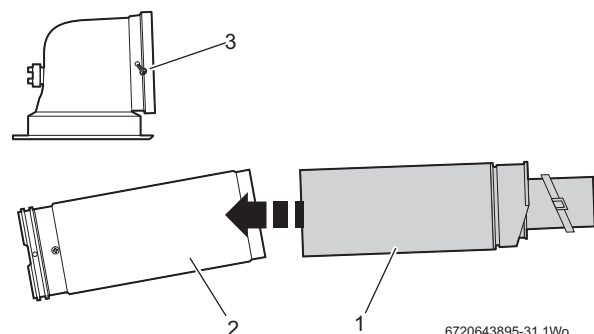

Fig. 29 Reducing the standard terminal

4.6.4 INSTALLING THE STANDARD FLUE

1. Set the flue length to the distance required, secure with screw and seal joint with the aluminium tape supplied.
Slide the inner wall seal (1) onto the terminal (2) as shown.
If fitting from inside the building; slide the outer wall seal (3) onto the terminal (2) as shown.

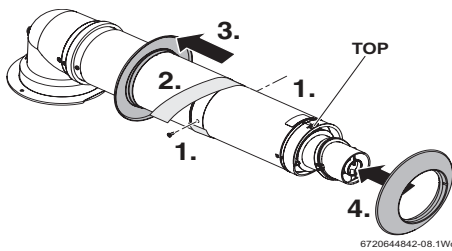

Fig. 30 Telescopic flue

2. Remove the three screws (4, 8) around the flue outlet (6) on the boiler. See screw pack in boiler.
Check the boiler flue seal is correctly seated.
Apply silicone grease to the boiler flue seal.
3. Position terminal (2) through the flue opening in the wall to the outside of the building by the distance shown.
The flue terminal MUST be fitted with the 'TOP' uppermost to allow the correct fit and use of the plume management system.
4. Align the flue turret (5) to the boiler flue outlet (6) with flat (7) facing to the rear of the boiler.
Push the flue turret (5) straight down into the boiler flue outlet (6).
For ease of assembly, locate screw (8) first and then fit screws (4) to secure flue turret (5).
If fitting from the outside of the building; slide the outer wall seal (3) onto the terminal (2) as shown.

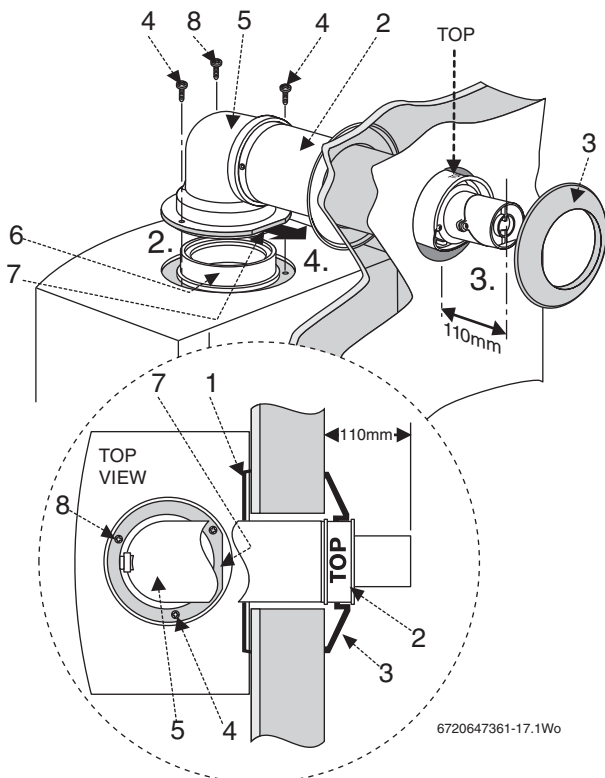

Fig. 31 Flue installation

4.6.5 FLUE TERMINAL PLUME RE-DIRECTION:

The flue discharge can be re-directed allowing some plume redirection control, alternatively, a complete plume management system can be fitted to the flue terminal.

RE-DIRECTING THE FLUE DISCHARGE

1. Using a suitable tool, release the clips (1 & 2) the terminal end and rotate through 180°.



NOTICE: DO NOT rotate the complete terminal assembly.

1. Refit to the terminal, ensuring that the clips (1 & 2) are engaged and secure.
2. Loosen screws (3) and rotate the entire outlet assembly to redirect the plume. Tighten screws (3) to secure in the required position.



The flue terminal outlet has built-in stops to limit rotation for horizontal flues to allow condensate to run back into the boiler for safe disposal. Do not attempt to force beyond the limit stops.

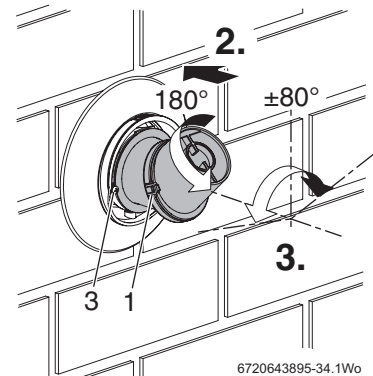
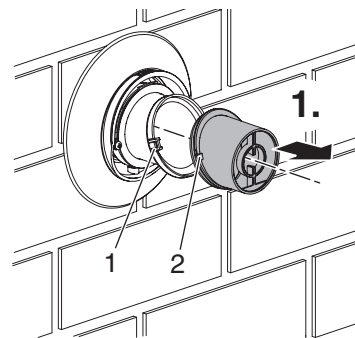

Fig. 32 Plume redirection



NOTICE: Outlet position

▶ The flue terminal outlet position must follow those stated in the relevant appliance instruction manual. When redirecting the flue discharge the outlet terminal must be at least 1500mm from any opening in the direction of the discharge to prevent combustion products from entering the building.

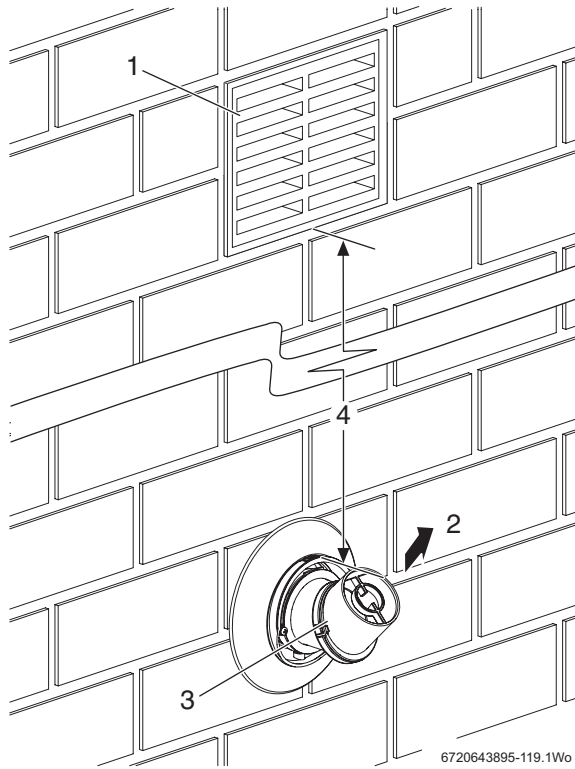

Fig. 33 Plume distance to opening

1	Opening in building
2	Flue discharge
3	Plume deflector
4	Minimum 1500mm from an opening in the building

4.7 CONDENSATE CONNECTION

Never terminate or discharge into any open source, including; sink, bath, shower, bidet, toilet etc.



Any external condensate pipe work of excessive runs should be protected with weather resistant insulation to help prevent freezing.

- ▶ Ensure that the condensate drain is 22mm diameter plastic pipe. It must fall at least 52mm per metre towards the outlet
- ▶ A 22mm adaptor pipe is contained in the fitting pack.

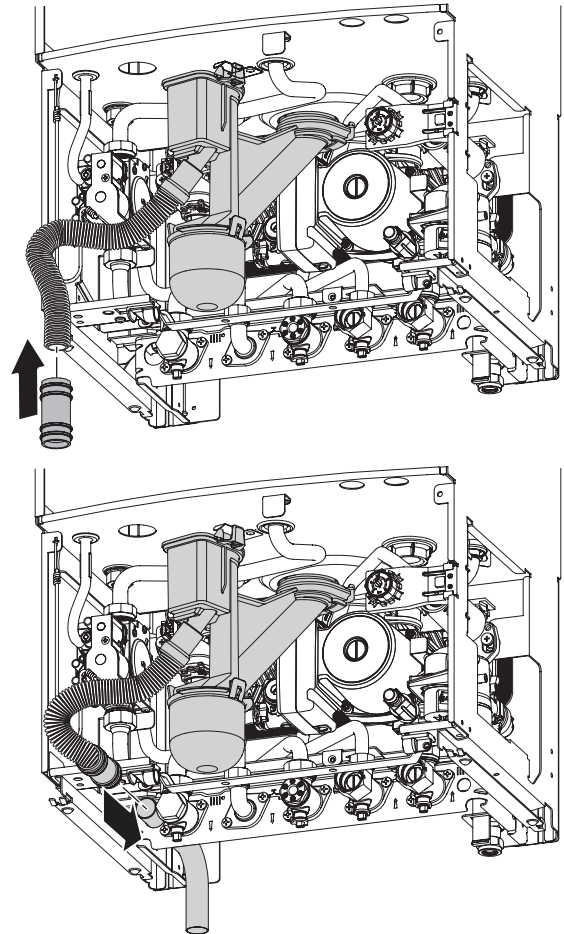



Fig. 34 Fitting siphon

4.8 ELECTRICAL

 **CAUTION:** ISOLATE THE MAINS ELECTRICITY SUPPLY BEFORE STARTING ANY WORK AND OBSERVE ALL RELEVANT SAFETY PRECAUTIONS

Danger of short circuit: When connecting the cables ensure that no cable pieces fall inside the control panel.

 Mains supply to the boiler must be through a fused double pole isolator situated next to the appliance. The isolator must have a contact separation of 3mm minimum in all poles.

Access to electrical connections:

- ▶ Remove boiler casing to access control panel.
- 1. Slide the white plastic clip down to release the control panel and lower into the service position.
- 2. Unscrew the three screws (B) on the back of the control panel and pull off the connections cover.
- 3. Unclip the cable clamp (C).
- 4. Cut off the tapered cable entry to fit cable diameter required.
- 5. Turn cable retaining screw (D) anti-clockwise. Run cable over the main crossbar and through the cable clamp (C), ensuring there is ample cable to reach the connectors. Turn cable clamping screw (D) clockwise to secure cable and replace clamp (C) into control panel.
- 6. Mains power 230 V connection (ST10):

- ▶ Separate wires from cable end and strip to 6mm
- ▶ Connect LIVE wire to terminal (L)
- ▶ Connect NEUTRAL wire to the terminal (N)
- ▶ Connect EARTH wire to the earth connector (⊥)

 Earth cable to be longer so that it pulls out last if mains cable is snagged.

- 7. Optional external frost thermostat connection (ST6):
- ▶ Connect frost thermostat supply LIVE to terminal (FS)
- ▶ Connect frost thermostat SWITCHED LIVE to terminal (FR)
- 8. 230V room thermostat and/or external timer (ST10):
- ▶ Remove link
- ▶ Connect room thermostat LIVE supply to terminal (LS)
- ▶ Connect room thermostat SWITCHED LIVE return to terminal (LR)
- ▶ Connect room thermostat NEUTRAL to terminal (NS)
- 9. Refit control panel cover:
- ▶ Refit panel and secure with screws (B).
- ▶ Bring the control panel to its upper position and secure by sliding the white plastic clip up.

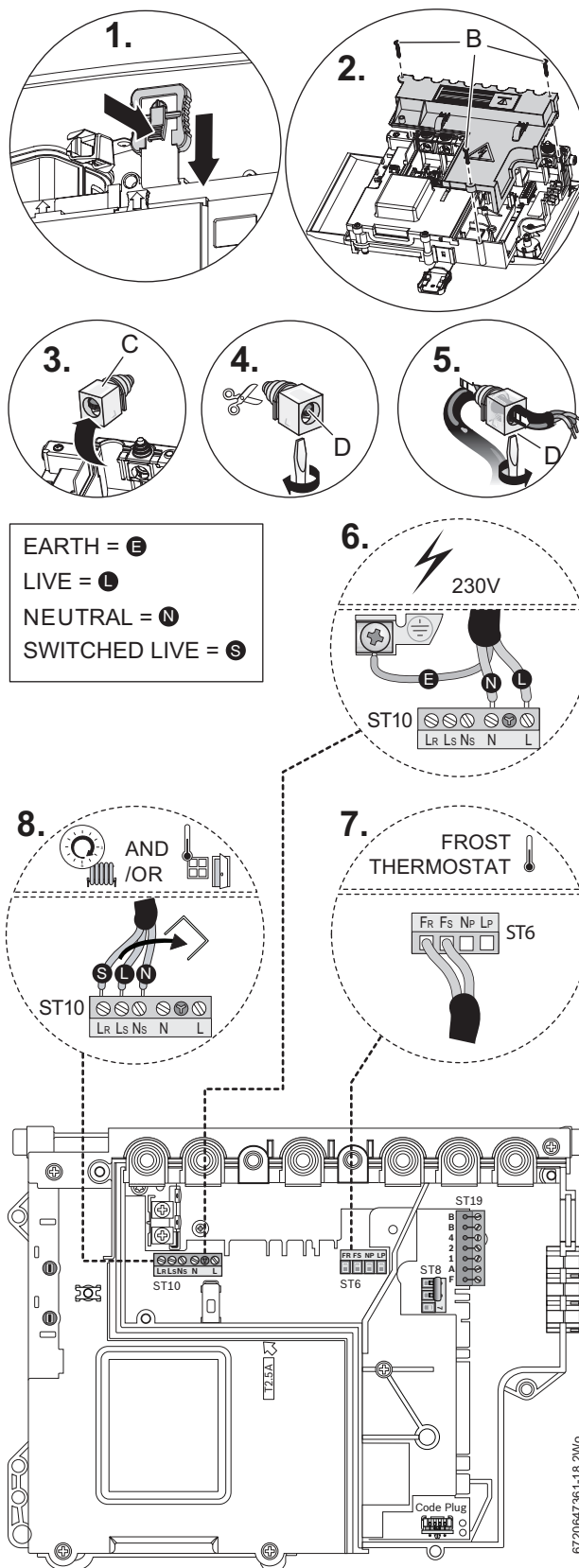
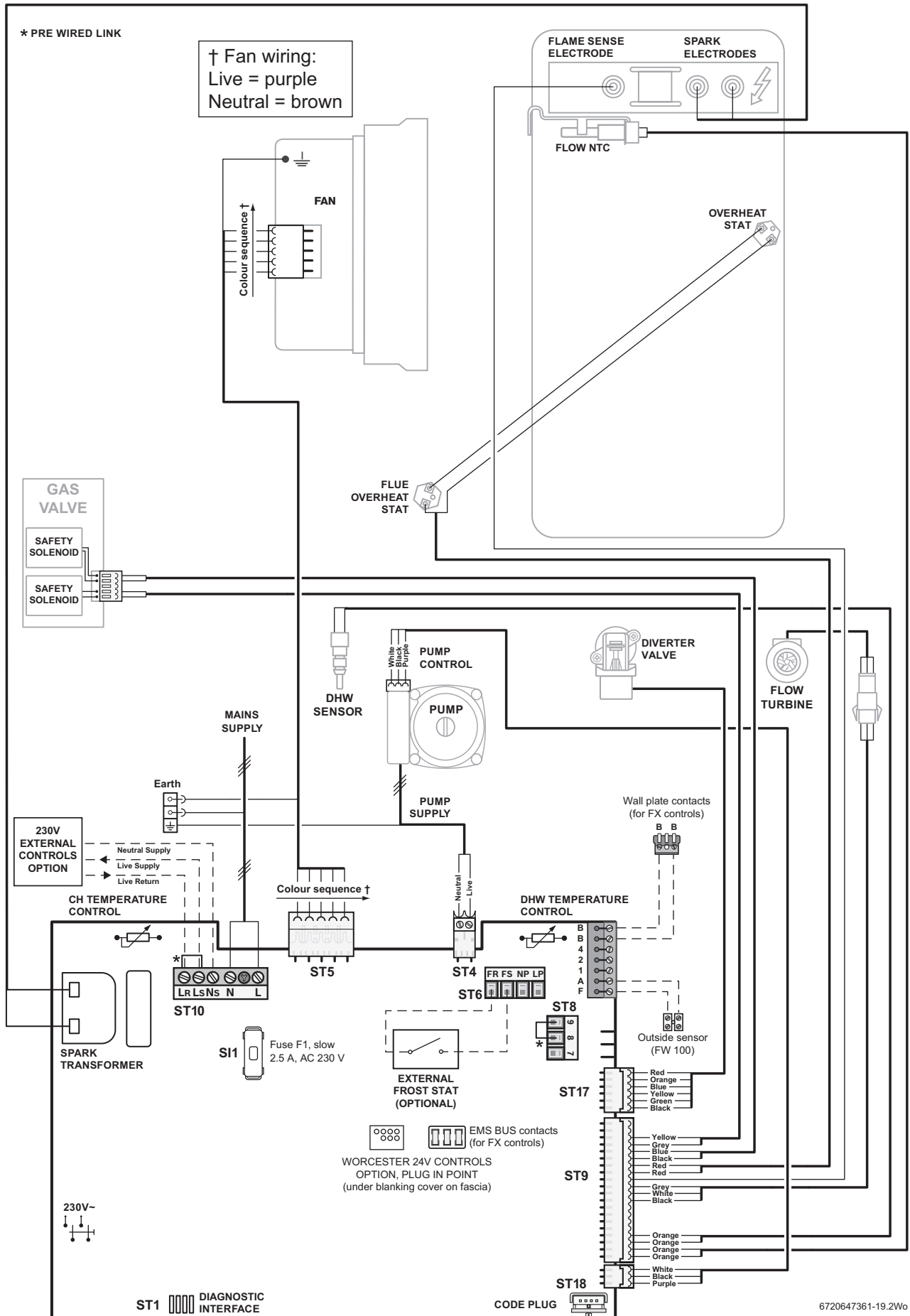

Fig. 35 Electrical connections

4.9 POSITION OF WIRED COMPONENTS



5 COMMISSIONING

5.1 PRE-COMMISSIONING CHECKS



CAUTION: ISOLATE THE MAINS SUPPLIES BEFORE STARTING ANY WORK AND OBSERVE ALL RELEVANT SAFETY PRECAUTIONS

1. Check that the service and water pipes are connected to the correct position on the manifold.

- A - CH flow (22mm)
- B - CH return (22mm)
- C - Gas inlet (22mm)
- D - DHW outlet (15mm)
- E - Cold water inlet (15mm)

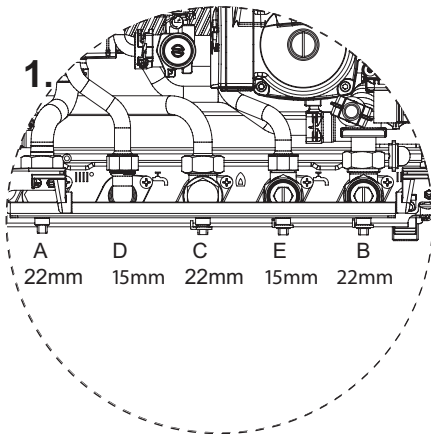

2. Check the gas type specified on the identification plate (F) matches that of the gas supply. Turn on the main gas supply, check the gas pipe work, connections and rectify any leaks.

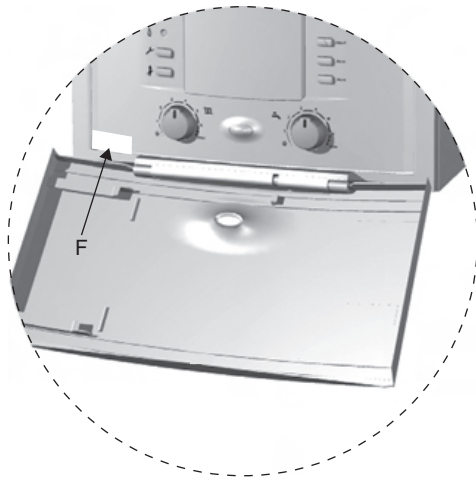

3. Check that the pressure relief connector, located on the right hand side at the bottom of the wall frame, is in the up position.

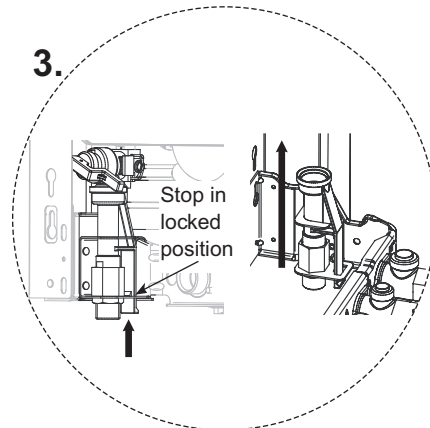

4. Check that the condensate pipe has been connected to the adaptor.

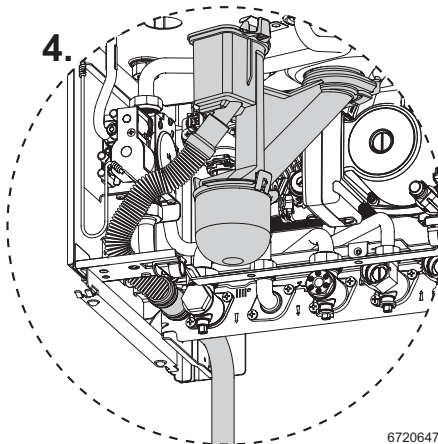

6720647361-20.2Wo



NOTICE: If the boiler is not to be commissioned immediately then: after successfully completing all of the checks and any rectification work, close the gas and water valves, shut off the gas supply and electrically isolate the boiler.

5.2 FILLING THE SYSTEM

1. Ensure all system and boiler drain points are closed.
 2. Remove the bottom panel (if fitted).
 3. Ensure that the white plastic control tap (C) on the charging link is turned fully into its closed position.
 4. Open the isolating valves on both the cold water inlet and CH return connections.
 5. Insert the charging key (D) (situated in its storage position (E) on the bottom cover of the boiler) initially aligning the arrow on the key with the "unlock" symbol on the charging link body. Ensure that the key is inserted fully and turn to the "lock" position. Check that the key is secure.
 6. To fill the system from the cold water inlet turn the white plastic control tap (C) on the charging link to the fully out position.
 7. Once the system has been filled to a pressure of 1bar turn the white control tap (C) to its closed position.
 8. Vent all radiators, retighten when completed and check the system and correct any leaks.
- The boiler integral expansion vessel is precharged to 0.75 bar (equal to a static head of 7.5 meters [22ft]). A Schraeder type valve is fitted to the expansion vessel to allow for pressure adjustment if required.
 - If an extra expansion vessel is fitted to the central heating return, adjust to the **same pressure** as the appliance internal expansion vessel, refer to separate instructions with the extra expansion vessel.

9. Refill the system up to 1 bar. Turn the white control tap (C) to its closed position and then remove the charging key by turning back to its "unlock" position and withdrawing.
10. Place the charging key (D) in its storage position (E) on the bottom cover of the boiler.

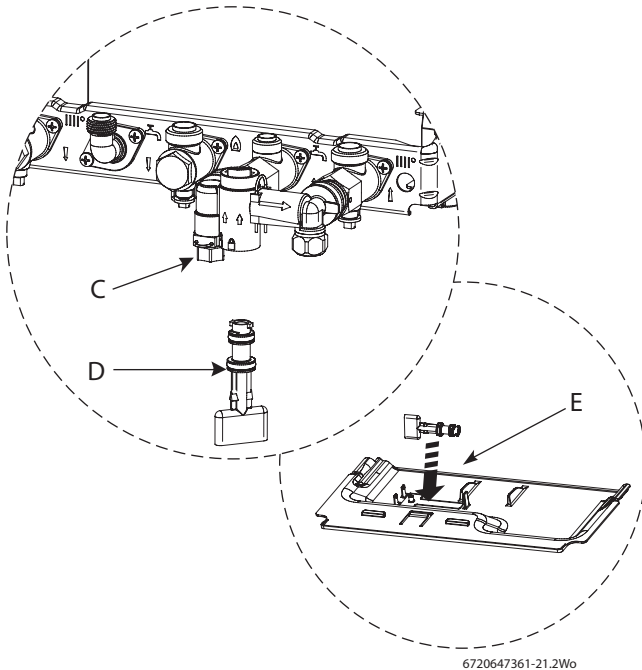

Fig. 36 Filling link key

GAS SUPPLY

- ▶ Open gas cock on the boiler and purge the gas supply to the boiler ensuring that the room is well ventilated.
- ▶ Test gas supply for tightness as described in BS 6891.

5.3 STARTING THE APPLIANCE

NOTICE: Never run the appliance when the appliance/system is empty or partially filled.

SWITCHING THE APPLIANCE ON/OFF:

1. Turn on mains power supply.
 - ▶ Turn on any external controls.
 - ▶ Set the thermostatic radiator controls to maximum temperature.
 - ▶ Set the clock/programmer to continuously ON and the room thermostat to maximum temperature.
 - A - On/off button
 - B - Cover or position for optional plug-in control
 - C - Display
 - D - System pressure gauge
 - E - Reset button
 - F - ECO button
 - G - Holiday button
 - H - DHW temperature control
 - I - Central heating temperature control
 - J - Performance test button
 - K - Service button
 - L - Burner indicator (GREEN)
 - M - On/off and fault indicator (BLUE)
 - N - Automatic air vent

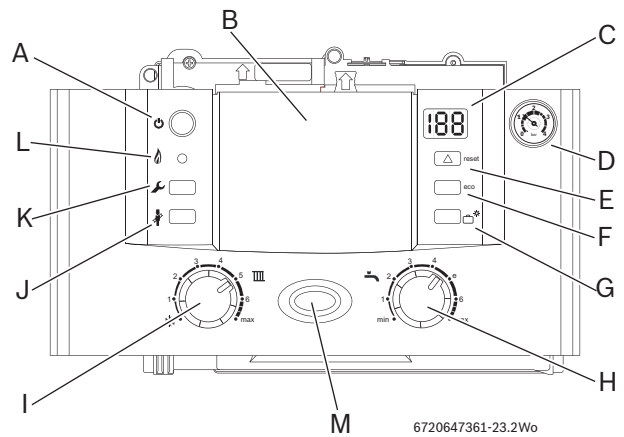

Fig. 37 Control panel

- ▶ Press button (A) and the power on indicator (M) illuminates BLUE. After a few seconds the display (C) will show the flow temperature.
- 2. Turn the CH temperature control (I) to maximum. The burner on indicator (L) illuminates GREEN when the burner has lit.

i

- ▶ The first time the appliance is switched on, a once-only venting function is activated. The heating pump then switches on and off at intervals. This sequence lasts about 8 minutes. The display shows in alternation with the CH flow temperature. Ensure that the automatic air vent (N) is open.
- ▶ The boiler then runs for 15 minutes at minimum heating output to fill the condensate trap, the display (C) alternates between "II" and the central heating flow temperature. This occurs every time the mains supply has been interrupted.

3. If the boiler fails to light the BLUE power indicator (M) and reset button (E) will flash alternately. To reset press and hold the reset button (E) for two seconds. The boiler will be reset.

CAUTION: DO NOT PRESS THE POWER INDICATOR (M) TO RESET THE BOILER.

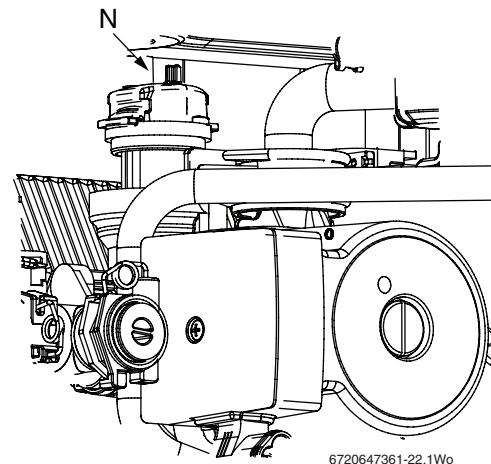

Fig. 38 Auto Air Vent

5.4 WATER TREATMENT

NOTICE:
▶ ARTIFICIALLY SOFTENED WATER MUST NOT BE USED TO FILL THE CENTRAL HEATING SYSTEM.

ENSURE THAT THE SYSTEM HAS BEEN CLEANED AS ON PAGE 9 OF THESE INSTRUCTIONS.

FLUSHING (Central Heating):

- ▶ Switch off the boiler.
- ▶ Open all drain cocks and drain the system while the appliance is hot.
- ▶ Close drain cocks and add a suitable flushing agent at the correct strength for the system condition in accordance with the manufacturer's instructions.
- ▶ Run the boiler/system at normal operating temperature for the time stated by the manufacturer of the flushing agent.
- ▶ Drain and thoroughly flush the system to remove the flushing agent and debris.

INHIBITOR (Central Heating):

- ▶ Check drain cocks are closed and all radiator valves are open before adding a suitable inhibitor compatible with aluminium (or combined inhibitor/anti-freeze if the system is exposed to freezing conditions) to the heating system water in accordance with the manufacturers instructions.

i The pH value of the system water must be less than 8 or the appliance guarantee will be invalidated.

- ▶ Fill the system to between 1 and 2 bar via the built-in charging link (filling loop) .
- ▶ Vent all radiators; tighten vents when complete.
- ▶ Re-pressurise if necessary to 1bar.
- ▶ Set all controls to maximum.
- ▶ Record the date when the inhibitor was added to the system on the guarantee card.

NOTICE:

- ▶ The concentration of inhibitor in the system should be checked every 12 months or sooner if system content is lost.
- ▶ The addition of sealing agents to the system water is not recommended as this can cause problems with deposits left in the heat exchanger.

5.5 COMMISSIONING

i When running in the performance test mode, the boiler will operate only the central heating circuit.

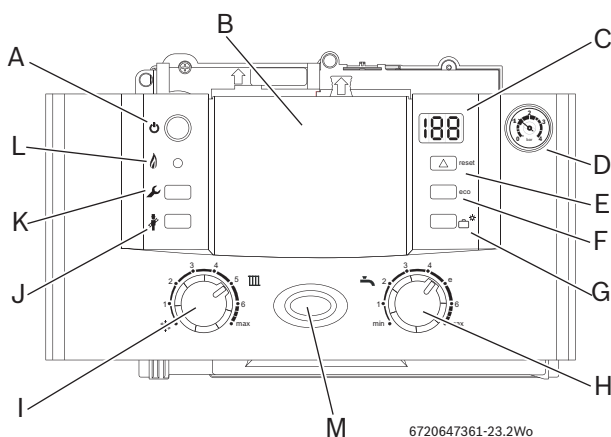

Fig. 39 Control panel

A	ON/OFF button
B	Cover or position for optional plug-in control
C	Display
D	System pressure gauge
E	Reset button
F	ECO button
G	Holiday button
H	DHW temperature control
I	Central heating temperature control
J	Performance test button
K	Service button
L	Burner indicator (GREEN)
M	On/off and fault indicator (BLUE)

NOTICE: The combustion for the appliance is factory set. No adjustment is required if the gas inlet pressure is correct.

5.5.1 CHECKING THE GAS INLET PRESSURE

The inlet pressure to the appliance must be checked using the following procedure:

MEASURING THE INLET PRESSURE

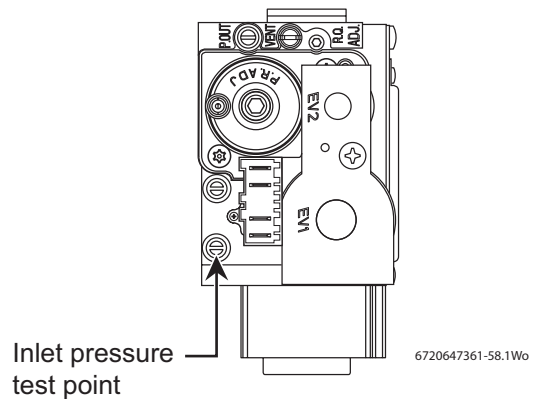

Fig. 40 Inlet pressure test point

- ▶ Close gas isolation valve.
- ▶ Slacken the screw in the inlet pressure test point a quarter turn and connect a manometer.
- ▶ Open gas isolation valve.
- ▶ Measure the pressure with the boiler running at maximum.
 - Press the Performance test button (J) for more than ten seconds and set Central Heating temperature to maximum.
 - The Performance test button (J) will illuminate continually and the display (C) will alternate between and the central heating flow temperature.
- ▶ Check the gas supply working pressure at the gas valve conforms to values shown in Fig. 41 or Fig. 42 .

i Ensure inlet pressure is satisfactory with all other gas appliances working.

NOTICE: Do not continue commissioning until the correct gas inlet pressure is achieved.

- ▶ If pressure is satisfactory press the Performance test button (J) again and the boiler will return to normal operation.

5.6 FINISHING COMMISSIONING



The boiler has been factory set, so there should be no need to adjust combustion settings.

REPLACE OUTER CASING:

1. Replace outer casing making sure that the securing points are properly located.

- ▶ Press the clip (A) downwards to secure casing on top.
- ▶ Retighten bottom two screws (B).

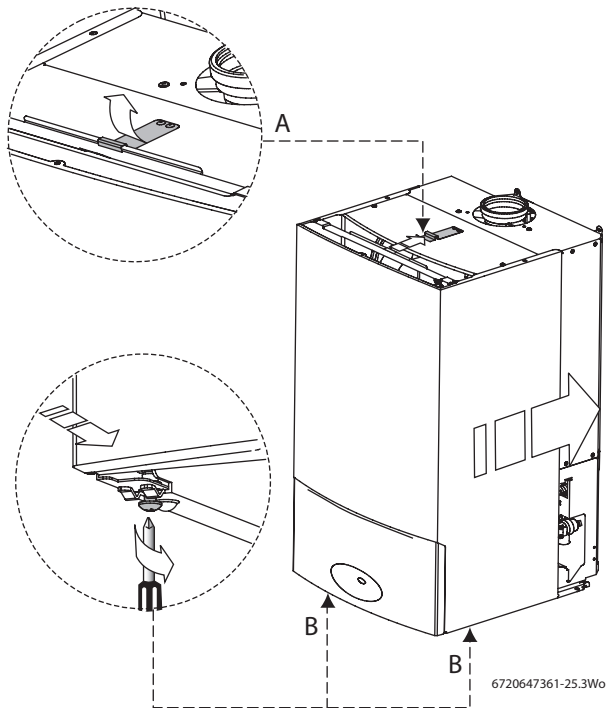

Fig. 43 Fitting outer case

INSTALLING BOTTOM PANEL:

2. The bottom panel slides onto two ledges (C) either side of the boiler frame.

- ▶ Hold the panel up against the underside of the boiler and slide towards the rear until it is fully engaged.

HANDOVER:

- ▶ Complete the Benchmark check list.
- ▶ The fascia cover is opened by pulling the flap (D) towards you.
- ▶ Set up the controls and show the user how to operate all the controls shown in the User Guide.
- ▶ If the appliance is unused and exposed to freezing conditions; shut off all the mains supplies and drain the system and boiler.

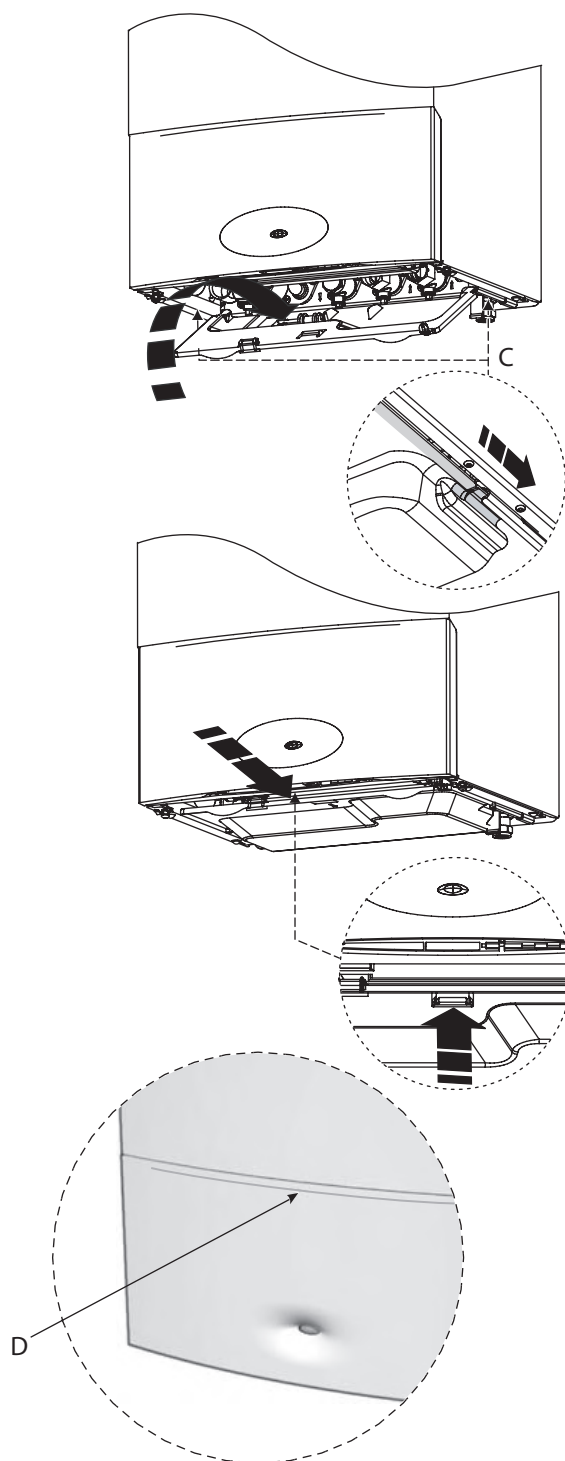

Fig. 44 Fitting bottom panel

6 SERVICING AND SPARES



CAUTION: TURN OFF THE GAS SUPPLY AND ISOLATE THE MAINS SUPPLIES BEFORE STARTING ANY WORK AND OBSERVE ALL RELEVANT SAFETY PRECAUTIONS.



NOTICE: After replacement of any components always check for gas tightness where relevant and carry out functional checks as described in the commissioning section.
Any O-rings and gaskets must be replaced.

6.1 INSPECTION AND SERVICE



NOTICE: SERVICE MUST **NOT** BE ATTEMPTED IF A CO/CO₂ ANALYSER IS **NOT** AVAILABLE.



NOTICE: Any service work must be carried out by competent registered engineers such as British Gas or Gas Safe registered engineer.



Please refer to the Service Record at the rear of the manual.

- To ensure the continued efficient operation of the appliance it must be checked at regular intervals.
- The frequency of servicing will depend upon the particular installation conditions and usage. However, an annual service is recommended.
- The extent of the service required by the appliance is determined by the operating condition of the appliance when tested by **fully qualified engineers**.
- The service interval record sheet at the rear of these instructions must be completed after each service.

INSPECTION

1. Check that the terminal and the terminal guard, if fitted, are clear and undamaged.
 2. If the appliance is in a compartment or cupboard check that the specified service space around the appliance is clear.
 3. Check all the joints and connections in the system and remake any that show signs of leakage. Refill and re-pressurise if applicable as described in Commissioning.
- Operate the appliance and make a note of any irregularities. Call up the last fault stored by the Bosch Heatronic, press the Service button and select Service Function **6.A**.
Use the ECO and Holiday buttons to scroll through the menu.
Refer to Fault Finding for rectification procedures.

6.1.1 COMPONENT ACCESS

Removing outer case

1. Remove bottom panel by pulling it forward and off.
2. Undo but do not remove the two screws (A) securing boiler casing at the bottom of the appliance.
3. Pull upwards to release the clip (B) on top of the boiler.
4. Pull case forward and remove.

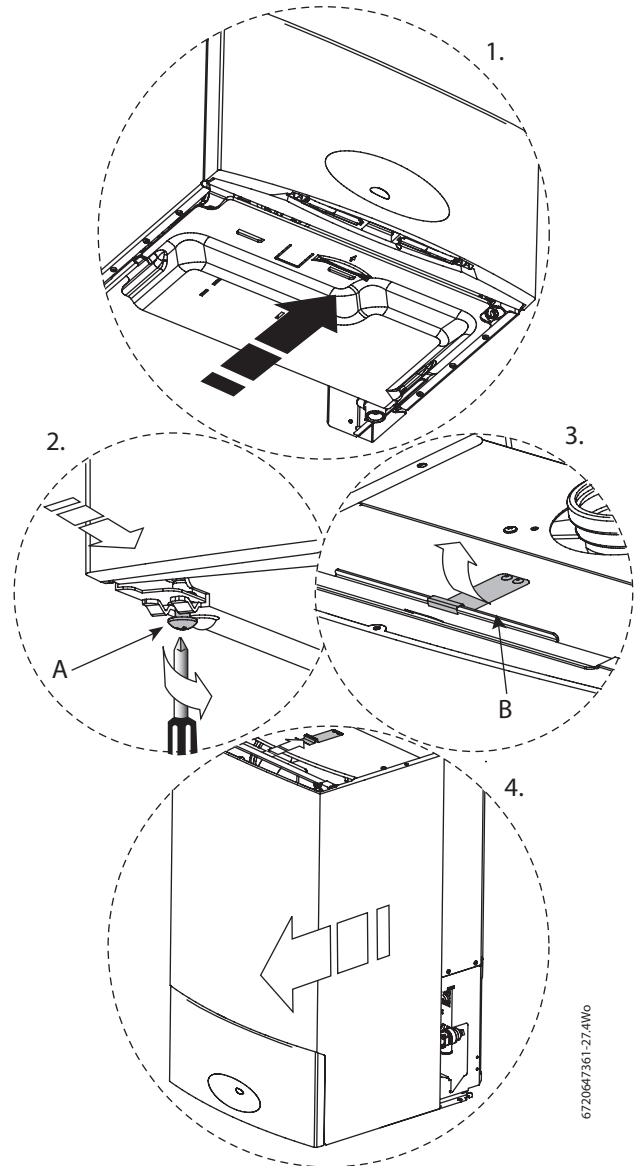

Fig. 45 Removing outer case

2. Adjusting boiler control to service position

1. Slide down the white plastic clip securing the control panel.
2. Pull the control panel forward until it comes to rest in service position.

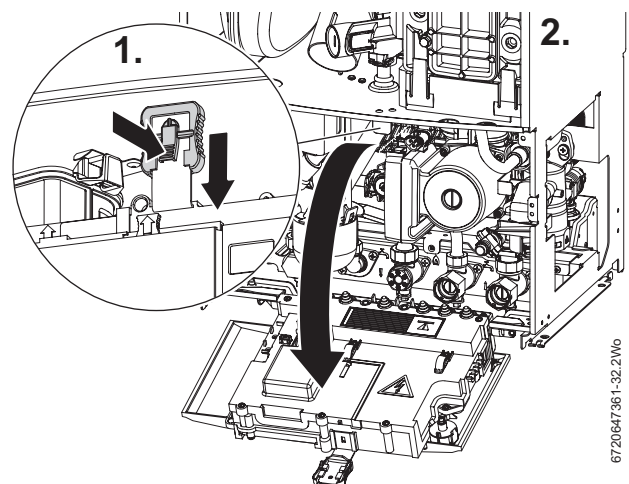

Fig. 46 Controls to service position

6.1.2 FAN PRESSURE TEST



This test is to determine if the heat cell requires cleaning/attention

SET THE BOILER TO MAXIMUM



- ▶ When running in the Performance test mode, the boiler will operate only the Central Heating circuit.
- ▶ The heating output can be limited to any level between minimum and maximum rated heat output to suit a specific requirement. Even when the heat output is limited, full heat output is still available for domestic hot water.

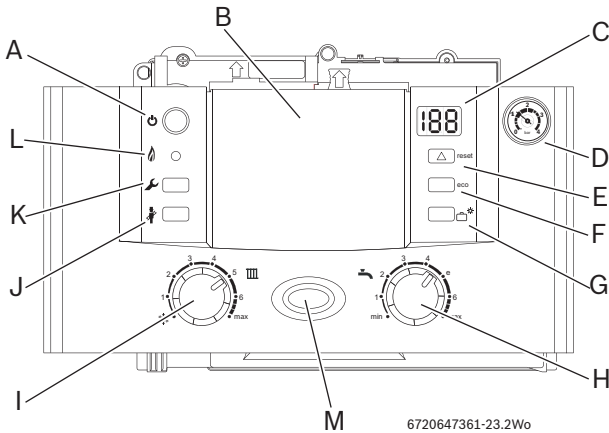

Fig. 47 Control panel

- [A] ON/OFF button
- [B] Cover or optional plug-in controller
- [C] Display
- [D] System pressure gauge
- [E] Reset button
- [F] ECO button
- [G] Holiday button
- [H] DHW temperature control
- [I] Central heating control
- [J] Performance test button
- [K] Service button
- [L] Burner indicator (green)
- [M] ON/OFF and fault indicator (blue)

- ▶ Press and HOLD the Performance test button (J) for 10 seconds and set Central Heating temperature to maximum.
 - The Performance test button will illuminate continually.
 - The boiler will stay in this mode for 15 minutes unless the Performance test button is pressed again.
- ▶ Pull the cover off and connect a manometer to the fan pressure test point.
- ▶ After measurement replace test point cover.

FAN PRESSURE TEST

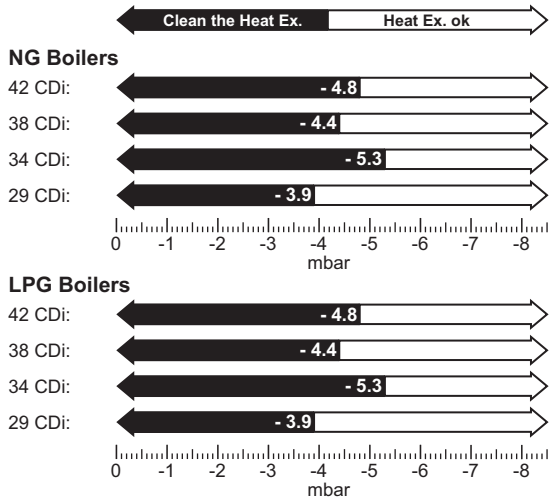

Fig. 48 Fan pressure readings

- Pressures readings in the black area will indicate that the heat exchanger requires attention/cleaning.
- There is a special accessory kit available specifically designed for cleaning the heat exchanger. Part number 7 719 001 996.

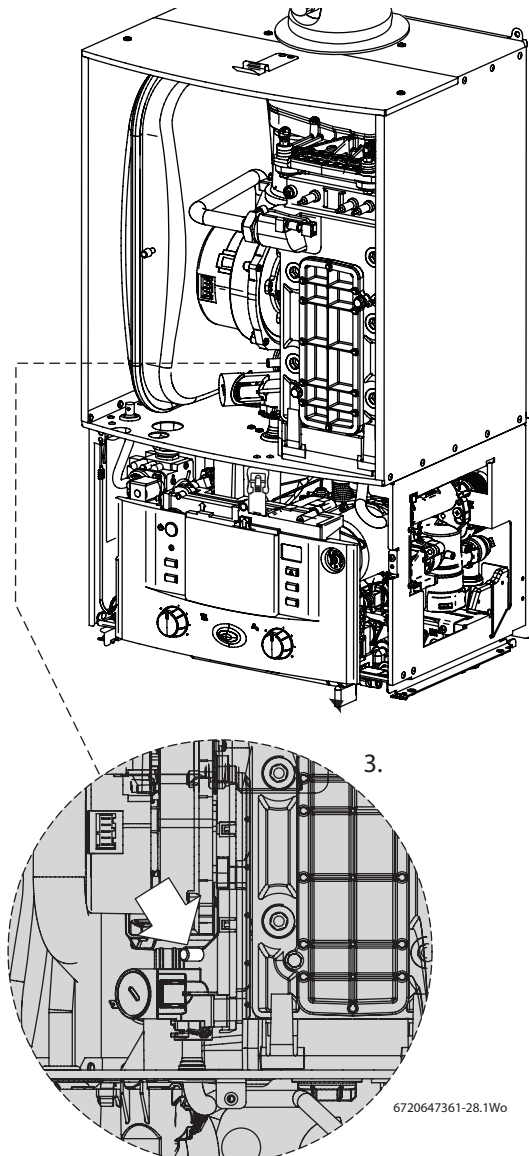

Fig. 49 Fan pressure test point

NOTICE: Air/Gas ratio

- ▶ After servicing the CO/CO₂ must be checked using the procedure in the section "Setting the air/gas ratio" on page 38.
- ▶ The setting of the air/gas ratio must be carried out by a competent person. Setting the air/gas ratio must not be attempted unless the person carrying out the operation is equipped with a combustion analyser conforming to BS 7927 and is competent in its use.

6.1.3 TO CLEAN THE HEAT EXCHANGER

- ▶ Remove outer case and base panel and isolate the appliance from power.
1. Remove cleaning access cover (B), seal (C) and metal plate (D) securing it, if present.

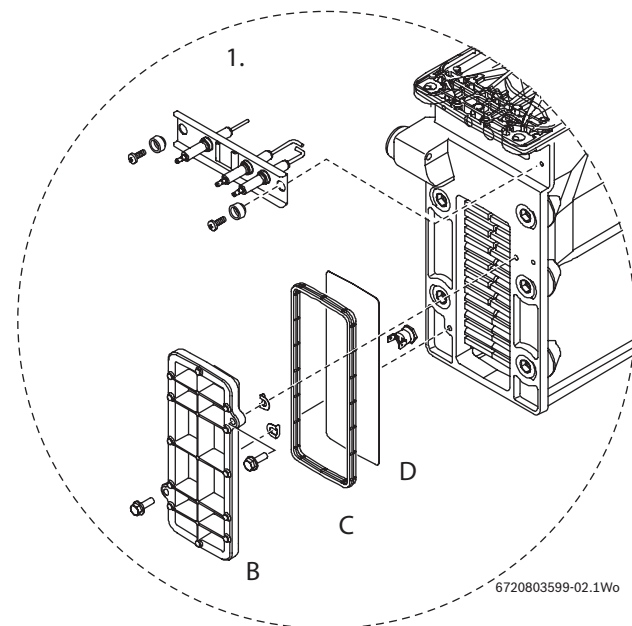
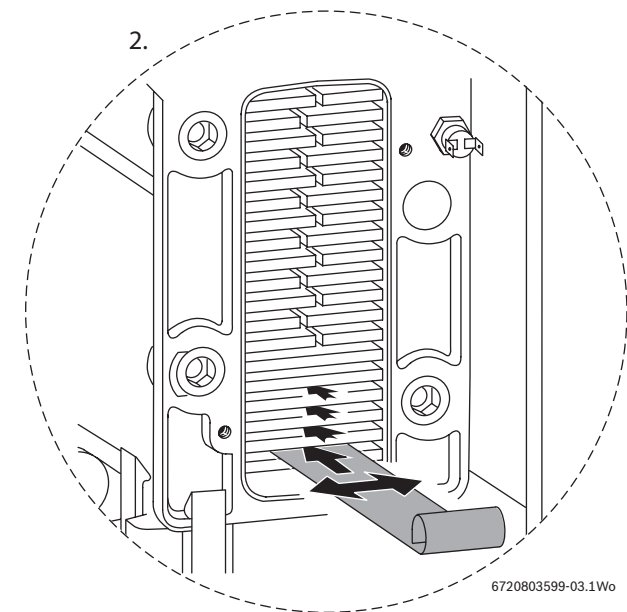
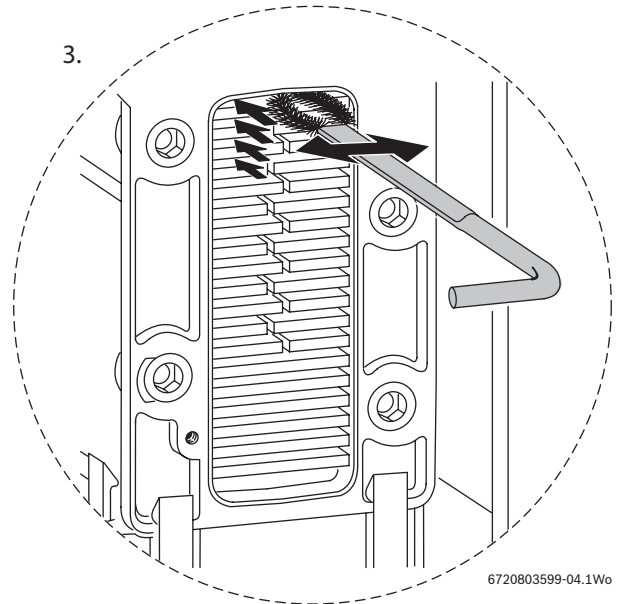

Fig. 50 Cleaning heat exchanger

2. Loosen any deposits in the heat exchanger from top to bottom using the cleaning blade.



3. Clean the heat exchanger from top to bottom using the brush.



- ▶ Refit the clean out cover plates in reverse order using a new seal (C) and tighten screws.

6.1.4 TO CLEAN THE BURNER

1. Remove cover panel (A) by removing the screws (B).
- ▶ Check that the boiler is completely isolated from the gas supply.

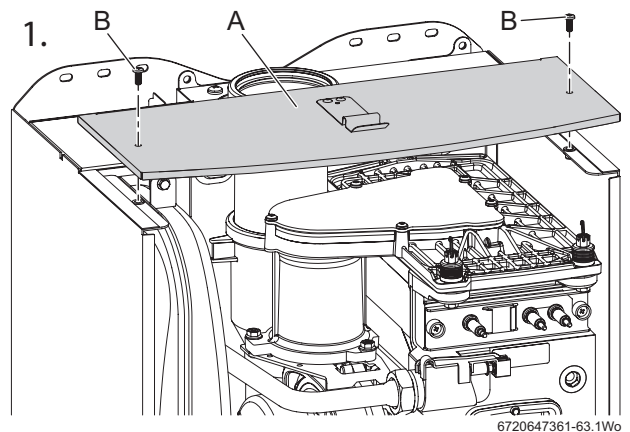

2. Remove the clips (C) and unscrew the two bolts (D).

 - ▶ Unscrew and remove the two hexagon screws (E) securing the fan.
 - ▶ Slacken fully the rear securing bolt (F).
 - ▶ Remove the burner cover plate (G).

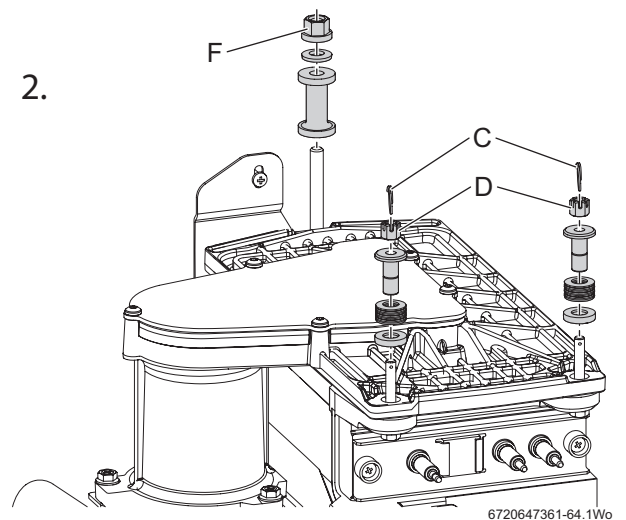

3. Remove the burner (H) and clean components.

Do not use a wire brush.

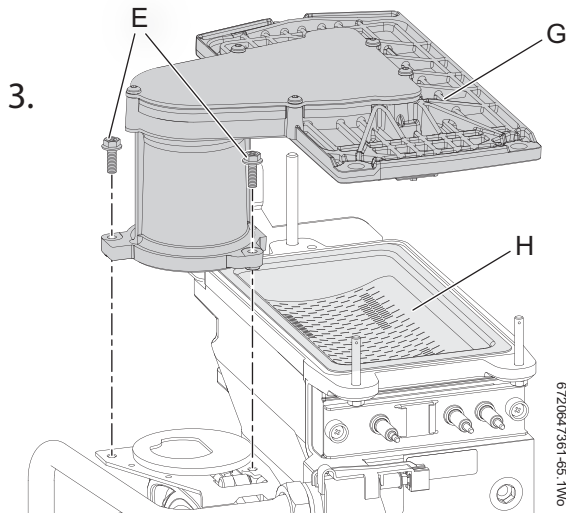

6.1.5 TO CHECK THE DIAPHRAGM IN BURNER COVER

4. Carefully withdraw diaphragm (J) from fan intake tube and check for soiling and splits.

- ▶ Carefully refit diaphragm (J) the correct way round into the fan intake tube, the diaphragm flaps must open upwards.
- ▶ Re-assemble burner in reverse order using a new seal (K).
- ▶ Adjust gas/air ratio. Refer to section "Setting the gas/air ratio".

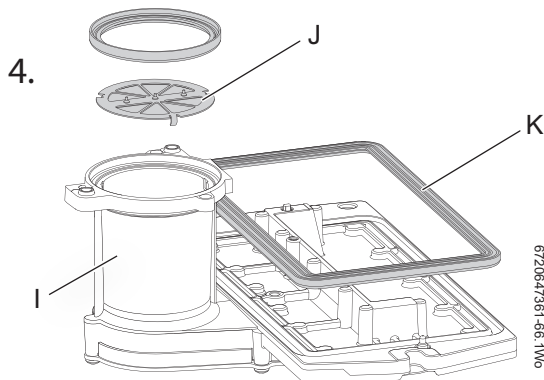

6.1.6 TO CLEAN THE CONDENSATE TRAP

1. Pull condensate pipe out of the adaptor.

2. Remove trap from boiler.

- ▶ Clean trap and check that the heat exchanger connection is clear.
- ▶ Fill the condensate trap with approximately 1/4 litre of water and refit in reverse order.

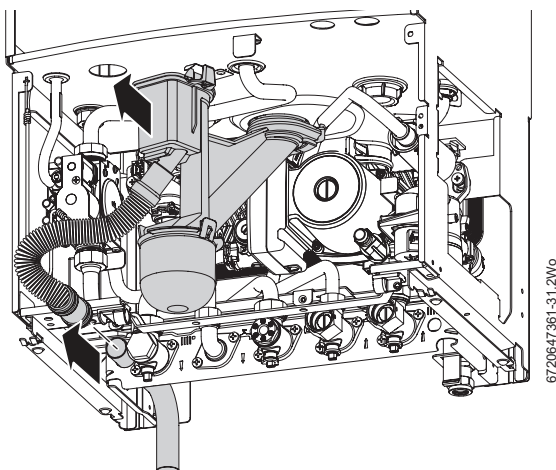

6.2 SETTING THE AIR/GAS RATIO



NOTICE: Air/Gas ratio

- ▶ The setting of the gas ratio must be carried out by a competent person.
- Setting the air/gas ratio must not be attempted unless the person carrying out the operation is equipped with a combustion analyser conforming to BS 7927 and is competent in its use.

SETTING THE CO₂



When running in the Performance test mode, the boiler will operate only the central heating circuit. To avoid the boiler cycling on low heating demands, remove the diverter valve motor from the valve body and run the domestic hot water tap throughout the Performance test mode. Refit the diverter valve motor once all the tests are completed, → page 44

1. Connect manometer to inlet test point on the gas valve.

- ▶ To adjust the CO₂ it will be necessary to first operate the boiler at maximum output.
 - ▶ Press and hold down the Performance test mode button for 10 seconds until illuminated.
2. Turn central heating control to maximum; the boiler will then go to maximum output.



The control will resume normal operation after 15 minutes or if the Performance test mode button is pressed for over a second.

3. Using a flat blade screwdriver set the CO₂ via the max adjuster referring to the table below.



CO₂ should be measured 10 minutes after firing the appliance.

Gas type	CO ₂ setting maximum	CO ₂ setting minimum
Greenstar 29 and 34CDi		
Natural gas	9.6% ±0.2	9.0% ±0.2
LPG	11.5% ±0.2	10.5% ±0.2
Greenstar 38 and 42CDi		
Natural gas	9.7% ±0.2	9.1% ±0.2
LPG	11.5% ±0.2	10.5% ±0.2

Table 10

- ▶ Check CO is less than 200 ppm.
 - ▶ Measure the gas inlet pressure at the gas valve test point; it should be no more than 2.5mbar less than the pressure at the meter for natural gas and no more than 4mbar less than the pressure at the regulator for LPG.
4. Set the central heating control to minimum. This will make the boiler go to minimum power.
5. Measure the CO₂; it should now be at the figure for minimum output.
- ▶ If not, use a 4mm Allen key to adjust the min adjustment on the gas valve until correct.
 - ▶ Return to maximum and re-check the CO₂.
 - ▶ If correct press and hold down the Performance test mode button for two seconds; the button will cease to be illuminated.
 - ▶ Remove manometer and re-seal inlet pressure point on gas valve.

- ▶ Fit new plastic sealing cover onto the max adjuster.
- ▶ Replace the brass screw over the min adjuster on the valve.
- ▶ Re-assemble and refit boiler case.

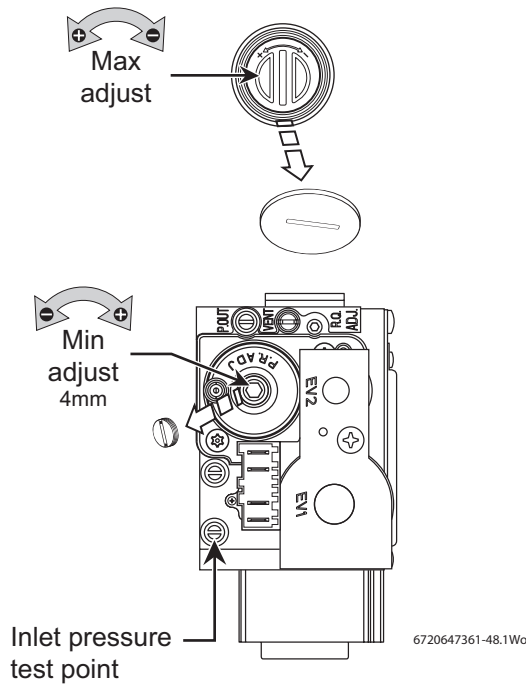

Fig. 51 Setting the Air/Gas ratio

6.3 REPLACEMENT OF PARTS

CAUTION: TURN OFF THE GAS SUPPLY AND ISOLATE THE MAINS SUPPLIES BEFORE STARTING ANY WORK AND OBSERVE ALL RELEVANT SAFETY PRECAUTIONS.

NOTICE: After replacement of any components always check for gas tightness where relevant and perform functional checks as described in the Commissioning section.
O-rings or gaskets must be replaced.

REMOVING OUTER CASE

1. Remove bottom panel by pulling it forward and off.
2. Loosen but do not remove the 2 screws (A) securing boiler casing at the bottom of the appliance.
3. Pull upwards to release the clip (B) on top of the boiler.
4. Pull case forward and remove.

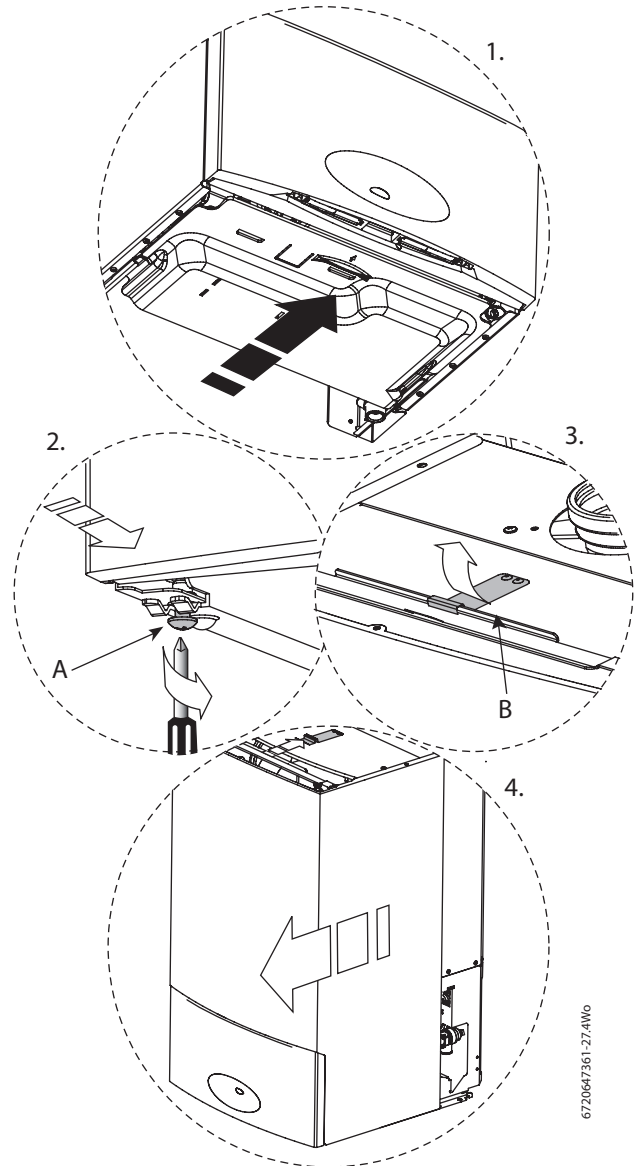

Fig. 52 Removing outer case

MOVING BOILER CONTROL TO SERVICE POSITION

1. Press in the centre of the white plastic clip securing the control panel and slide down to release.
2. Pull the control panel forward into the service position.

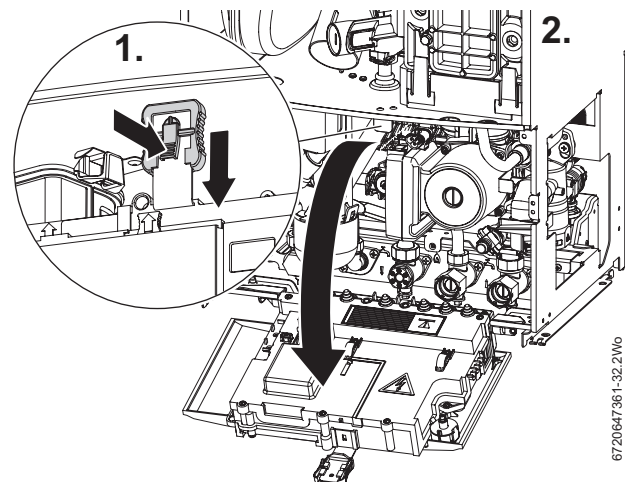

Fig. 53 Controls to service position

3. PRIMARY SENSOR

- ▶ Press retaining clip on plastic moulding and pull upwards until clear of pocket in heat exchanger.
- ▶ Separate sensor from connector, coat new sensor with heat conductive paste and replace.

4. OVERHEAT THERMOSTAT

- ▶ Remove two electrical connectors from thermostat.
- ▶ Unscrew the sensor.

5. FLUE LIMIT THERMOSTAT

- ▶ Remove electrical connections.
- ▶ Push the flue limit thermostat into the sump.
- ▶ Retrieve the thermostat from the sump well.

6. EXPANSION VESSEL

- ▶ Drain the appliance.

6.1 Remove locking screw (D).

6.2 Undo the union connection (E) at the bottom of the expansion vessel.

- ▶ Remove expansion vessel from boiler.

- ▶ Set the pressure of the new vessel to that required by the system.

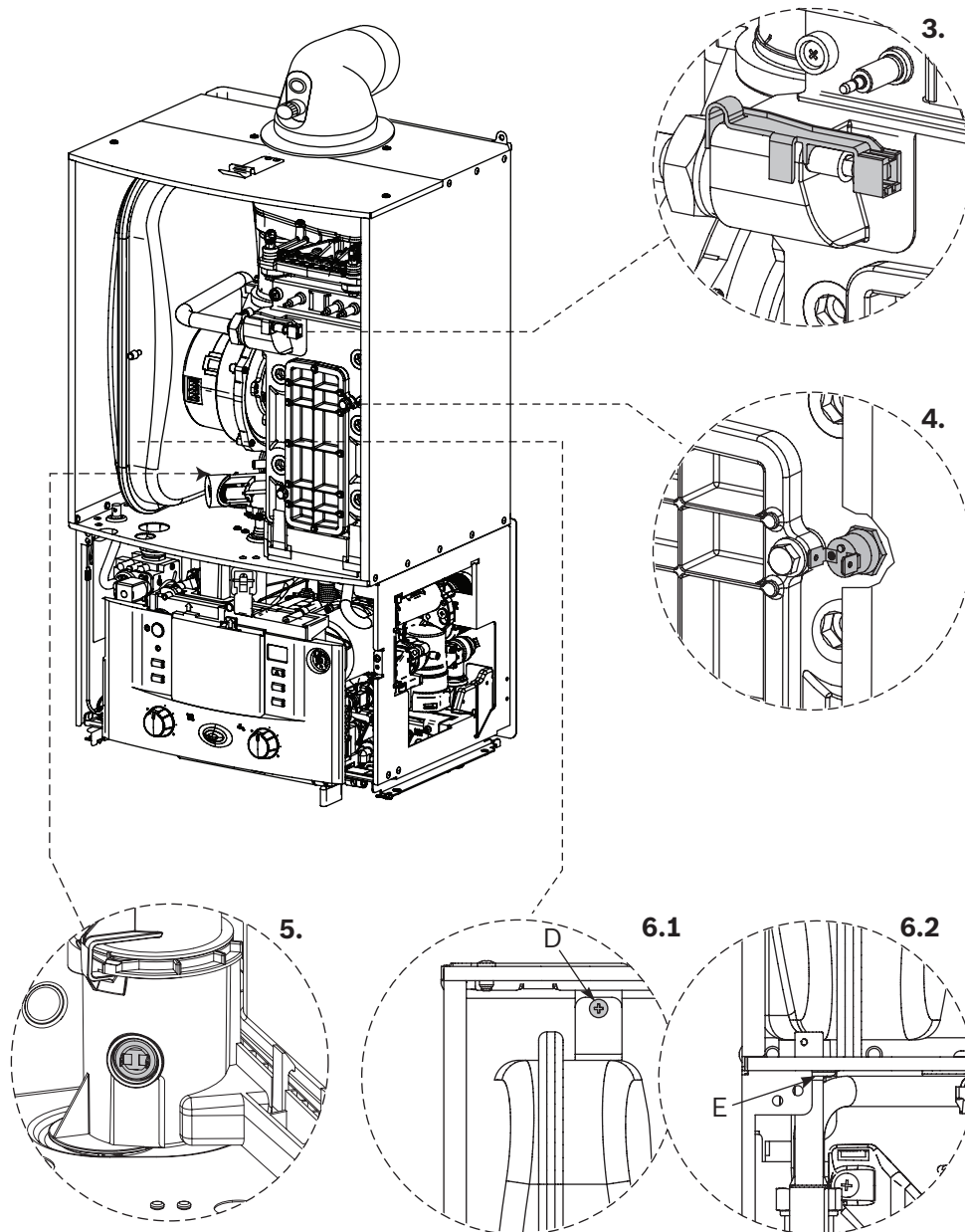

6720647361-33.1Wo

Fig. 54 Replacing parts

7. GAS VALVE

- ▶ Isolate gas supply at boiler gas cock.
- ▶ Pull out air inlet tube (A).
- ▶ Undo top gas connection (B) to gas valve.
- ▶ Undo bottom gas connection (C) to gas valve.
- ▶ Undo two securing screws (D) on the underside of casing.
- ▶ Pull valve up and forward out of boiler.
- ▶ Disconnect electrical connections.
- ▶ Replace valve with new seals and check for gas tightness.



The valve will require setting, follow procedure "Setting the air/gas ratio" in the Servicing and spares section.

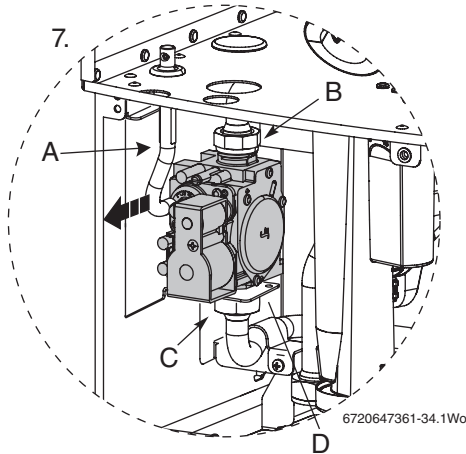

Fig. 55 Gas valve removal

8. SIPHON

To remove and replace the siphon:

- ▶ Pull condensate pipe out of the adaptor.
- ▶ Remove siphon from the boiler.
- ▶ Fit the new siphon to the sump and ensure that condensate discharge pipe is firmly connected to the outlet pipe work.

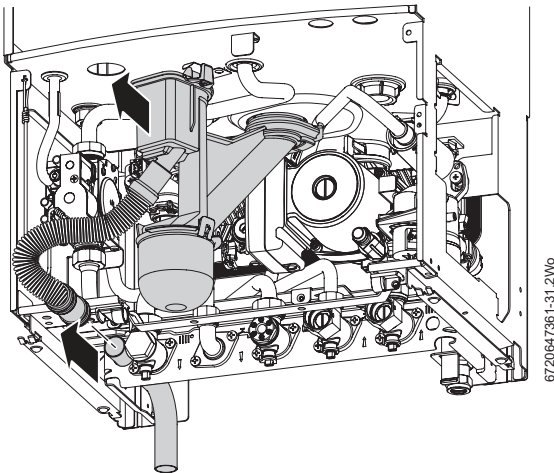

Fig. 56

9. ACCESS TO BOILER CONTROL COMPONENTS

- ▶ Remove 3 screws (A) and remove cover from control.

10. PCB FUSE

- ▶ Remove fuse (B) from the PCB and replace.
- ▶ There is a spare fuse clipped into the cover.

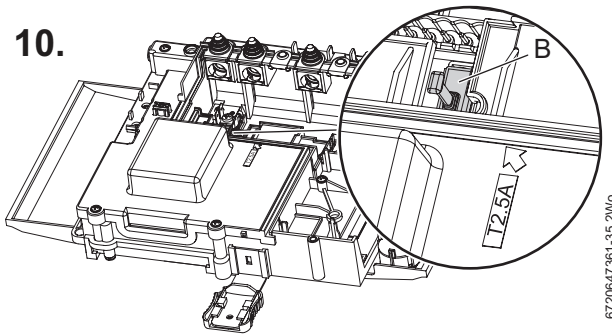
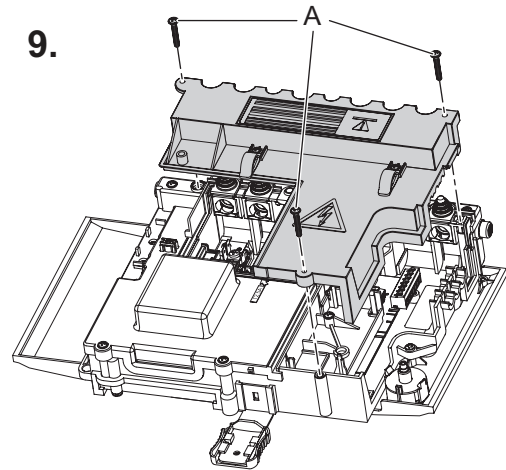

Fig. 57 Component and fuse access

11. PCB REMOVAL

To gain access to the PCB:

- ▶ Remove the five screws shown in the diagram below and remove the PCB cover.

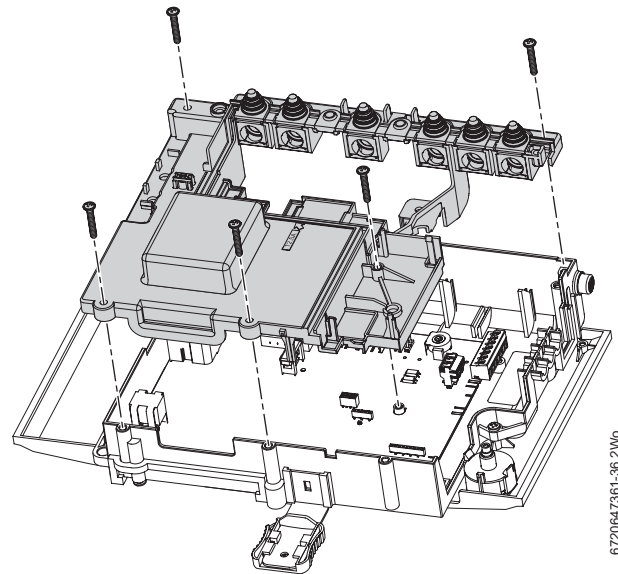

Fig. 58 PCB access

12. FAN ASSEMBLY

NOTICE: Air/Gas ratio

- ▶ After re-assembly the combustion must be checked using the procedure in the section "Setting the air/gas ratio."
- ▶ The setting of the gas ratio must be carried out by a competent person. Setting the air/gas ratio must not be attempted unless the person carrying out the operation is equipped with a combustion analyser conforming to BS 7927 and is competent in its use.

- ▶ Remove electrical connector from fan.
 - ▶ Remove condensate trap (see page 37).
1. Undo the union connection (A) from the top of the gas valve.
 - ▶ Remove wire clip (B) from air/gas adjustment assembly (C) then pull gas pipe down.
 2. Unscrew two screws (D).
 3. Remove fan from boiler.
 4. Remove three screws retaining the air/gas adjustment assembly (E).
 - ▶ Reassemble with new fan ensuring that seals are correctly fitted.

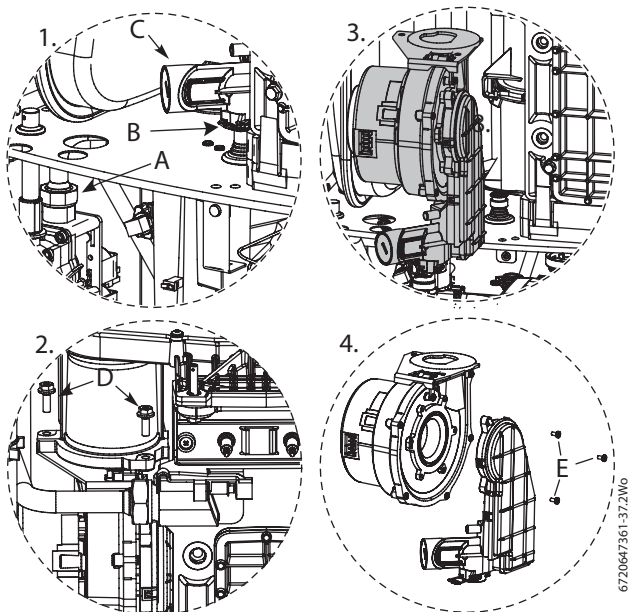

Fig. 59 Fan assembly removal

13. ELECTRODE ASSEMBLY

WARNING: Electrode gasket

- ▶ Do not remove the electrode assembly unless a new gasket and heatshield are available for re-assembly.

- ▶ Disconnect spark electrodes and flame sensor connection.
- ▶ Remove two screws (F).
- ▶ Remove spark/flame electrode assembly (G) from heat exchanger.
- ▶ Inspect the spark/flame electrode assembly and ceramics for signs of contamination or damage, replace as necessary.
- ▶ If necessary, clean the spark/flame electrode assembly with a plastic scouring pad.
- ▶ Replace electrode gasket and heatshield.

- ▶ Re-assemble with the new gasket and secure with the screws (F) removed earlier.

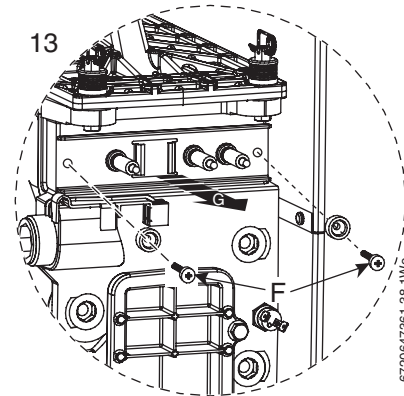

Fig. 60 Electrode assembly

14. AIR/GAS MANIFOLD

WARNING: Air/Gas manifold

- ▶ Do not remove the manifold unless a new gasket is available for re-assembly.

1. Remove cover panel (A) by removing screws (B).
- ▶ Check that the boiler is completely isolated from the gas supply.

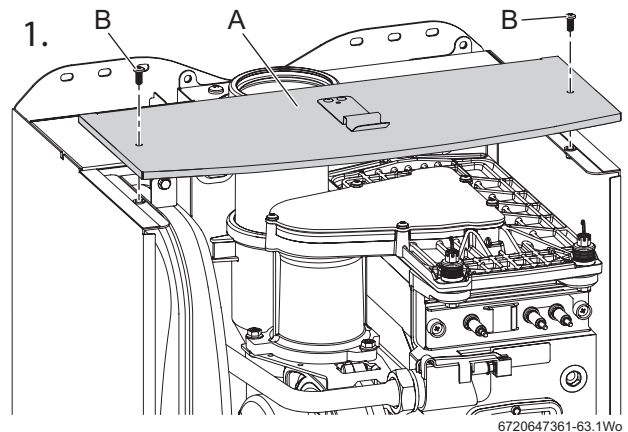

Fig. 61 Top panel

2. Remove clips (C) and unscrew the two bolts (D).
- ▶ Unscrew and remove the two hexagon screws (E) securing the fan.
- ▶ Slacken fully the rear securing bolt (F).

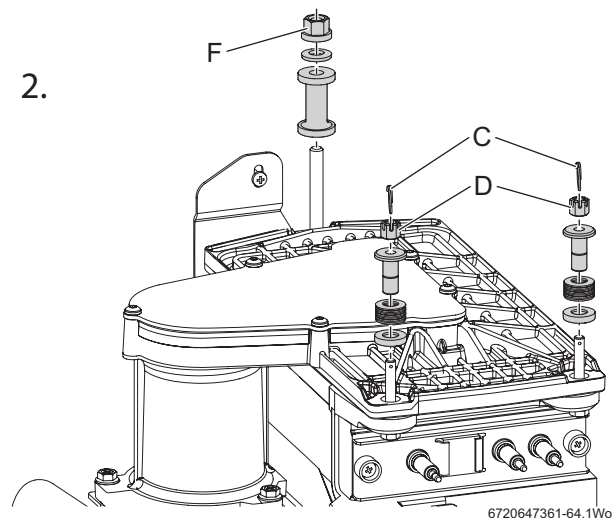

Fig. 62 Release air/gas manifold

3. Remove air/gas manifold (I)

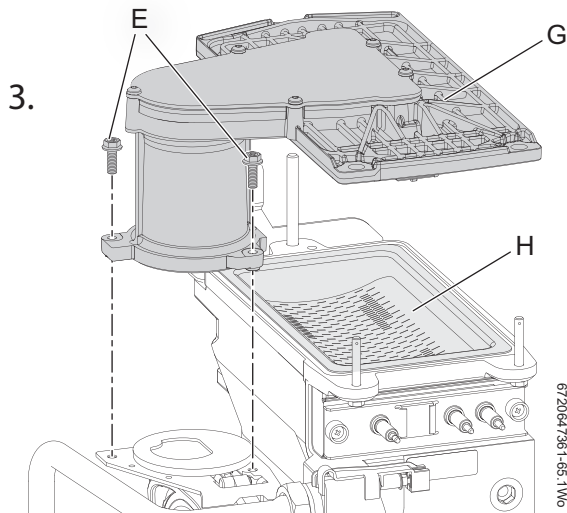

Fig. 63 Air/gas manifold

4. Open air/gas manifold (I).

- ▶ Carefully withdraw diaphragm (J) from fan intake tube and check for soiling and splits.

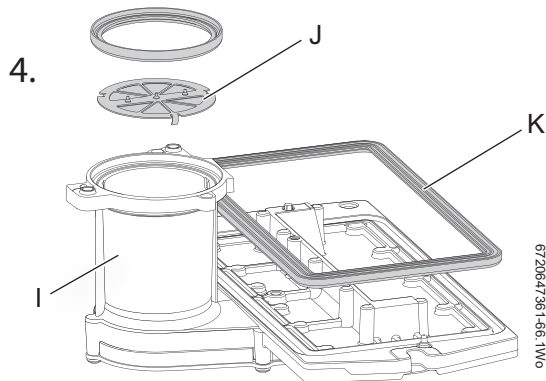

Fig. 64 Diaphragm

15. BURNER

- ▶ Remove the burner (H).
- ▶ Replace new burner in correct position.
- ▶ Ensure that a new seal (K) is used, refer to fig. 64.

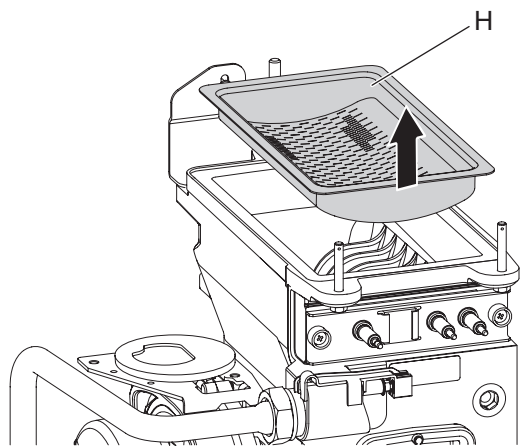
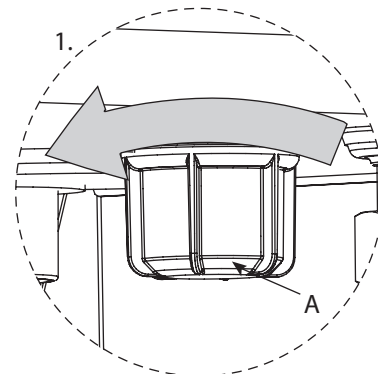

Fig. 65 Burner removal

16. HEAT EXCHANGER

- ▶ Isolate flow and return valves and drain the boiler.
- ▶ Remove condensate trap (see page 41).
- ▶ Remove fan assembly (see page 42).

1. Remove plastic nut (A) from the base of the inner casing



6720647361-67.1Wo

Fig. 66 Heat exchanger removal 1

2. Remove return pipe at the bottom of heat exchanger.

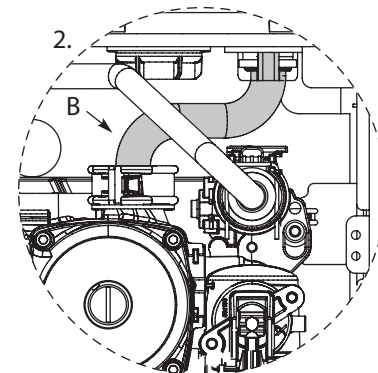

6720647361-68.1Wo

Fig. 67 Heat exchanger removal 2

3. Remove screw at the top of the heat exchanger (C).

- ▶ Unscrew the flow pipe (D).

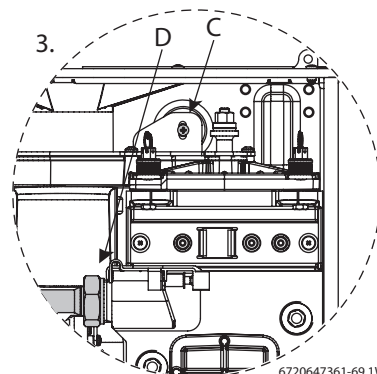

6720647361-69.1Wo

Fig. 68 Heat exchanger removal 3

4. Undo flue connection (E) from sump (F).

- ▶ Pull flue pipe up.
- ▶ Remove the heat exchanger.

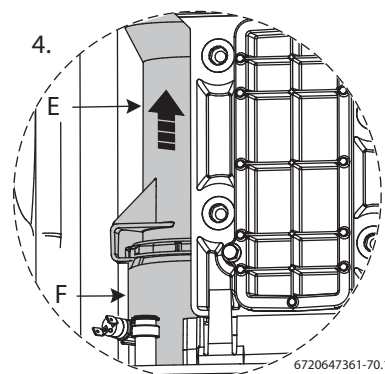

6720647361-70.1Wo

Fig. 69 Heat exchanger removal 4

17. DIVERTER VALVE MOTOR

There is no need to drain the appliance.

- ▶ Disconnect the electrical connector from the diverter valve motor.
- 1. Pull the motor assembly (A) towards you.
The assembly will slide free from the valve.
- ▶ To refit, follow the above in reverse.



In case of problems when refitting the motor: Connect the electrical connector to the motor and switch the appliance on. Then the motor goes to the middle position and you can refit it without difficulty.

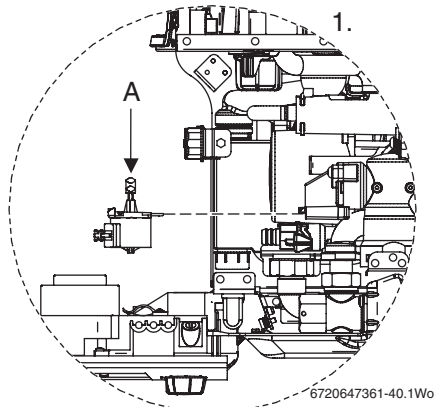

Fig. 70 Diverter valve motor removal

18. DIVERTER VALVE

- ▶ Ensure the appliance has been fully drained.
- ▶ Disconnect the electrical connector from the diverter valve motor.
- ▶ Undo the two screws holding the valve to the plastic housing.

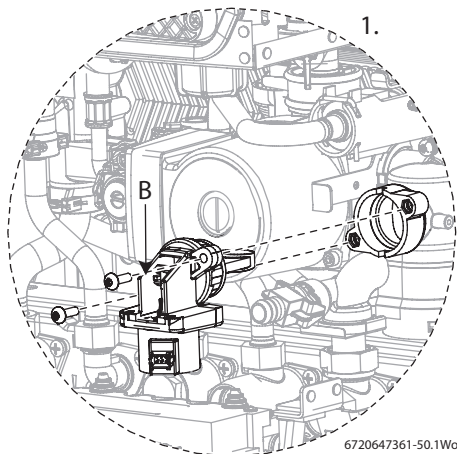

Fig. 71 Diverter valve removal

1. Withdraw the valve (B) and clean the valve chamber if necessary.
- ▶ To refit, follow the above in reverse.
Ensure any seals that have been disturbed are renewed.

19. AUTO AIR VENT

- ▶ Ensure the appliance has been fully drained.
- 1. Use a screwdriver or similar to rotate the air vent anticlockwise.
- 2. Lift the air vent (C) out of the housing and remove.
- ▶ To refit, follow the above in reverse.

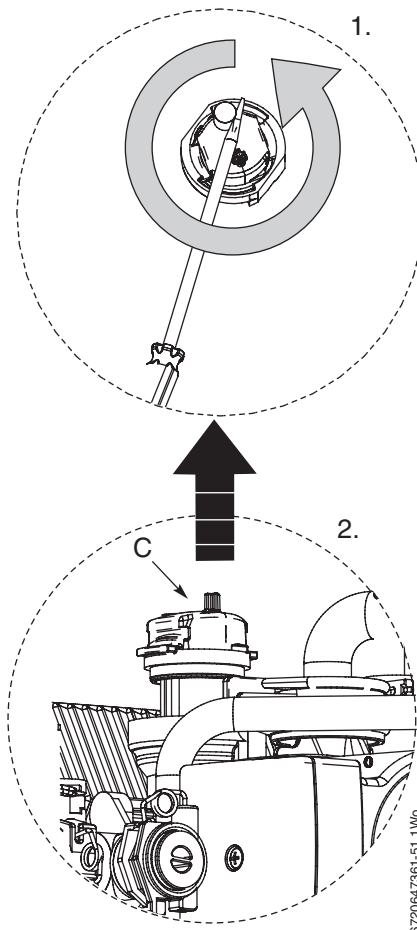

Fig. 72 Auto Air Vent removal

20. DHW TEMPERATURE SENSOR

- ▶ Ensure the domestic hot water circuit is fully drained.
- ▶ Disconnect the electrical connection from the sensor.
- ▶ Withdraw the spring clip.
- ▶ Withdraw the sensor (D) from the housing.
- ▶ To refit, follow the above in reverse.

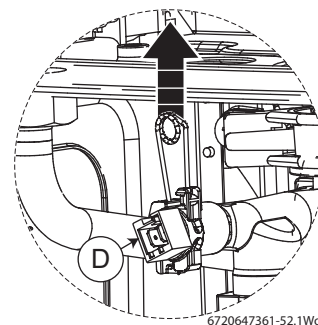

Fig. 73 DHW Temperature sensor removal

21. PUMP HEAD

- ▶ Ensure the appliance has been fully drained.
- 1. Disconnect the pump connections following steps i to iv.
- 2. Remove the four Allen bolts (A) securing the pump at each corner.
- 3. Gently pull the pump towards you and remove.
- ▶ To refit, follow the above in reverse.

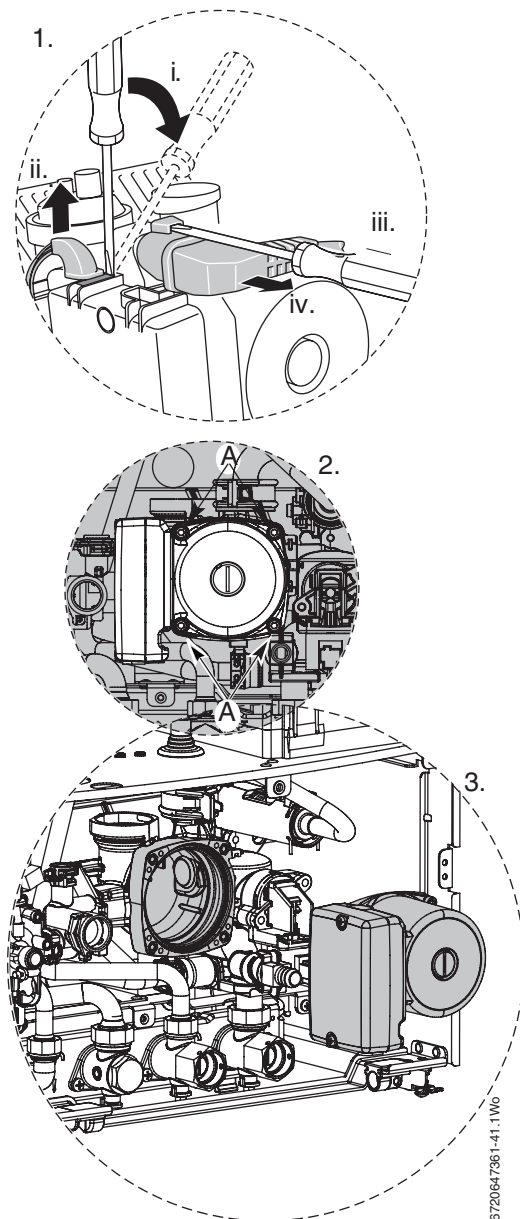

Fig. 74 Pump head removal

22. PRESSURE GAUGE

- ▶ Ensure the appliance has been fully drained.
- ▶ Withdraw the spring clip from the pressure sensing head housing.
- ▶ Undo the nut on the rear of the pressure gauge.
- ▶ Remove the pressure sensing head and pressure gauge capillary from the housing.
- ▶ To refit, follow the above in reverse.

DO NOT leave out the washer from the capillary when fitting a replacement gauge.

23. FLOW SENSOR, FLOW RESTRICTOR HOUSING AND FILTER

- ▶ Ensure the domestic hot water circuit is fully drained.
- ▶ Disconnect the electrical connection to the turbine.
- ▶ Remove the spring clip from the housing and move the brass pipe to one side.
- 1. Withdraw the flow sensor and filter from the housing.

- ▶ Using the cartridge tag, withdraw the flow restrictor housing.
- ▶ If the regulator housing has become stuck, a pair of long nosed pliers may be used to grip the housing.
- ▶ To refit, follow the above in reverse.
- ▶ Ensure any seals that have been disturbed are renewed.

24. FLOW RESTRICTOR

- ▶ Remove the flow restrictor housing (See Removing the flow sensor, flow restrictor and filter).
- 2. Using a small Allen key or similar, push the flow restrictor cartridge out of its housing.
- ▶ To refit, follow the above in reverse.
- Ensure any seals that have been disturbed are renewed.

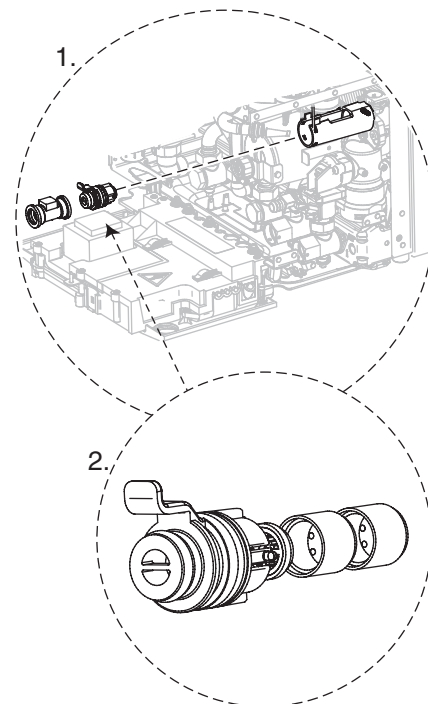

Fig. 75

25. DRAIN TAP

- ▶ Ensure the appliance has been fully drained.
- 1. Rotate the drain tap fully anticlockwise.
- 2. Withdraw the drain tap from its housing.
- ▶ To refit, follow the above in reverse.
- Ensure any seals that have been disturbed are renewed.

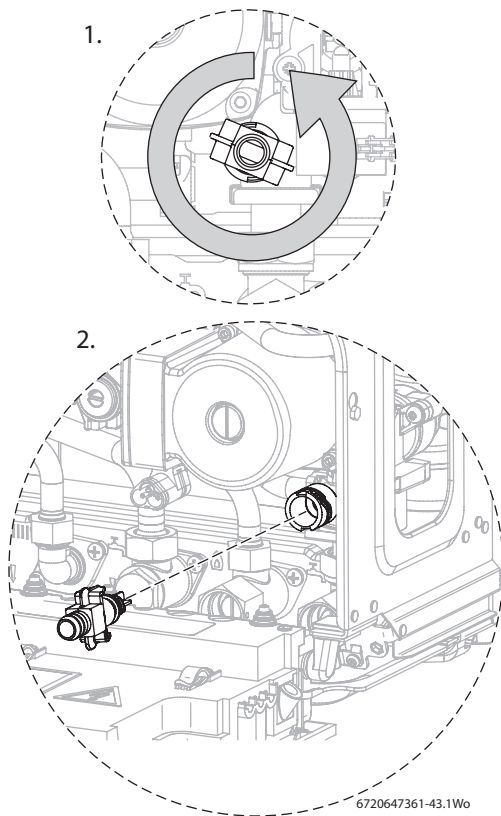

Fig. 76 Drain tap removal

26. HYDRAULIC BLOCK

- ▶ Ensure the appliance has been fully drained.
 - ▶ Disconnect the electrical connections to the NTC, Turbine and pump.
 - ▶ Undo the nuts securing the copper water pipes to the manifold (there is no need to remove the gas pipe).
 - ▶ Release the spring clips securing these water pipes to the plastic housing and remove the pipes.
 - ▶ Release the spring clip securing the expansion vessel pipe to the plastic housing and remove the pipe.
 - ▶ Undo the nut securing the pressure gauge to its bracket and remove the gauge.
 - ▶ Disconnect the pipe work to the pressure relief valve.
 - ▶ Release the locking devices that secure the two copper water pipes leading to the combustion chamber by squeezing the two tabs together and rotating anticlockwise (viewed from above).
1. Undo the two screws securing the hydraulic block to the chassis (located top left/top right of the housing).
 2. Lift the left hand side of the block slightly, then manoeuvre the block out, starting with the right hand side.
- ▶ Take care not to snag the harness or pressure gauge bracket.



The block will still contain a small amount of water, which will spill if the block is tilted.

- ▶ To refit, follow the above in reverse. Ensure any seals that have been disturbed are renewed.

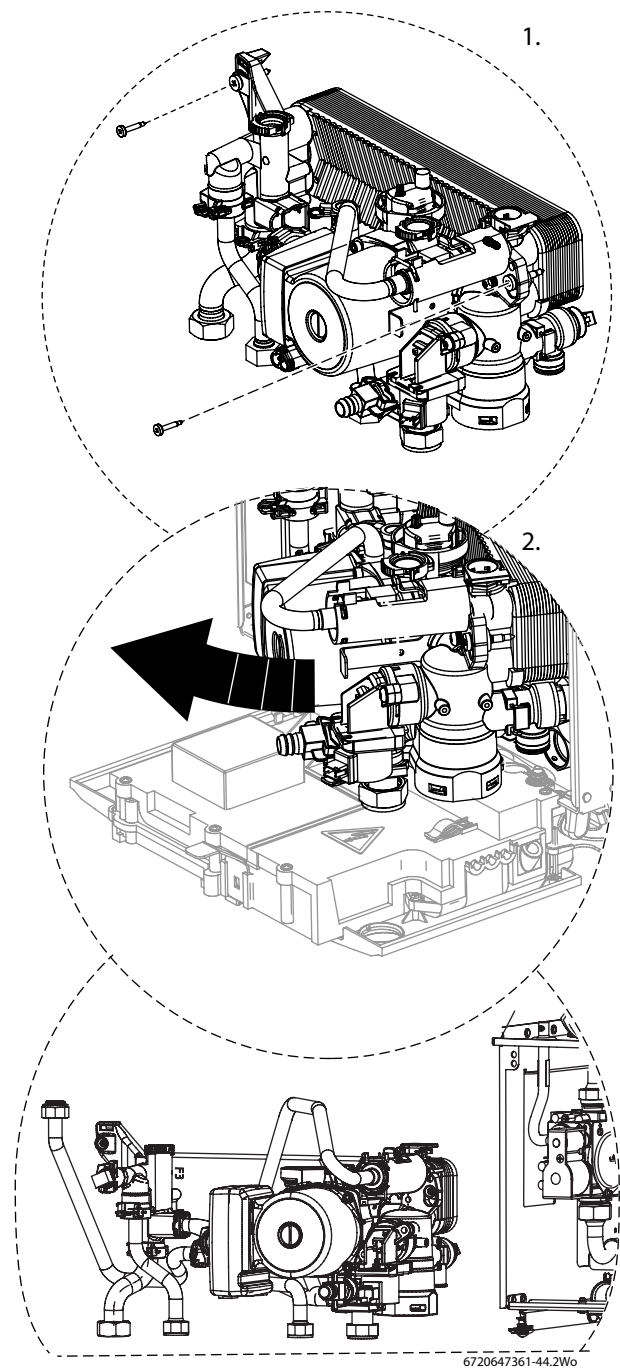

Fig. 77 Hydraulic block removal

27. CH PRESSURE RELIEF VALVE

- ▶ Remove the Hydraulic block from the boiler (See Removing the Hydraulic Block).

1. Remove the spring clip from the Pressure relief valve housing.
 2. Withdraw the pressure release valve (A) from its housing.
- ▶ To refit, follow the above in reverse.
 - ▶ Ensure any seals that have been disturbed are renewed.

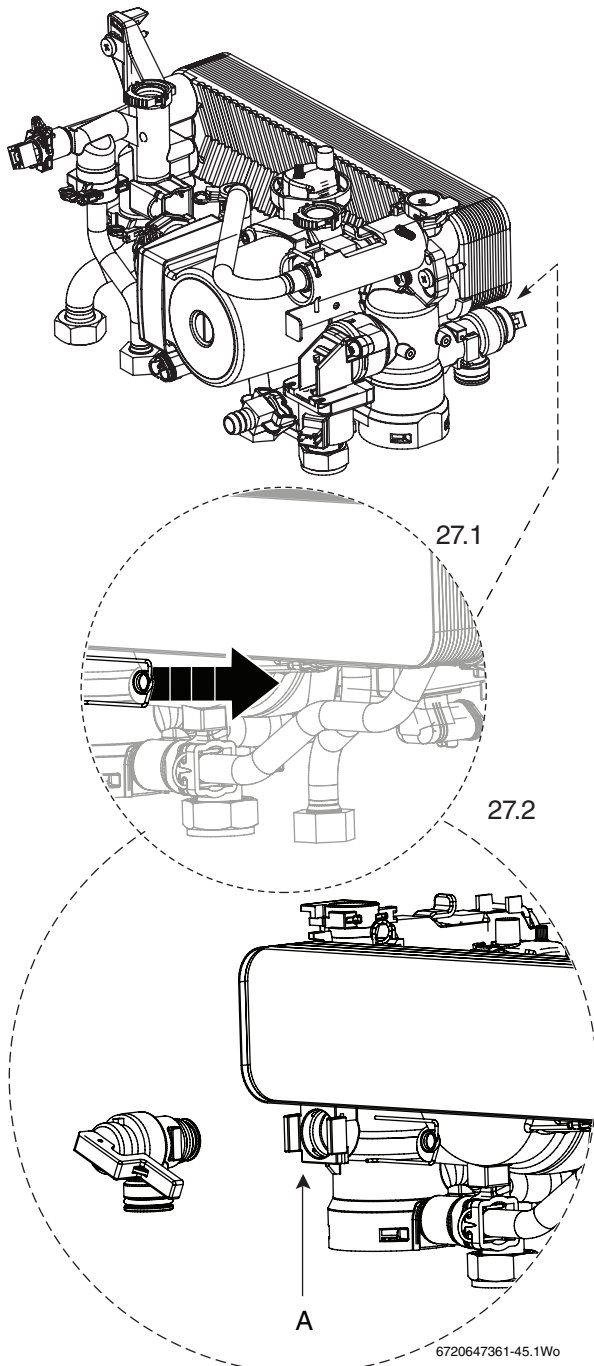

Fig. 78 Pressure relief valve removal

28. PLASTIC PROTECTION DEVICE

- ▶ Ensure the system is fully drained.
 - ▶ Disconnect all pipes connected to the pump housing.
 - ▶ Remove the electrical connection to the pump.
 - ▶ Withdraw the metal clip to the right of the pump head to release the pump housing.
 - ▶ Slide the device to the left and then withdraw it from the appliance.
1. Remove the spring clip from the pressure relief valve housing.

2. Withdraw the pressure relief valve (A). To refit, follow the above in reverse.
- ▶ Ensure any seals that have been disturbed are renewed.

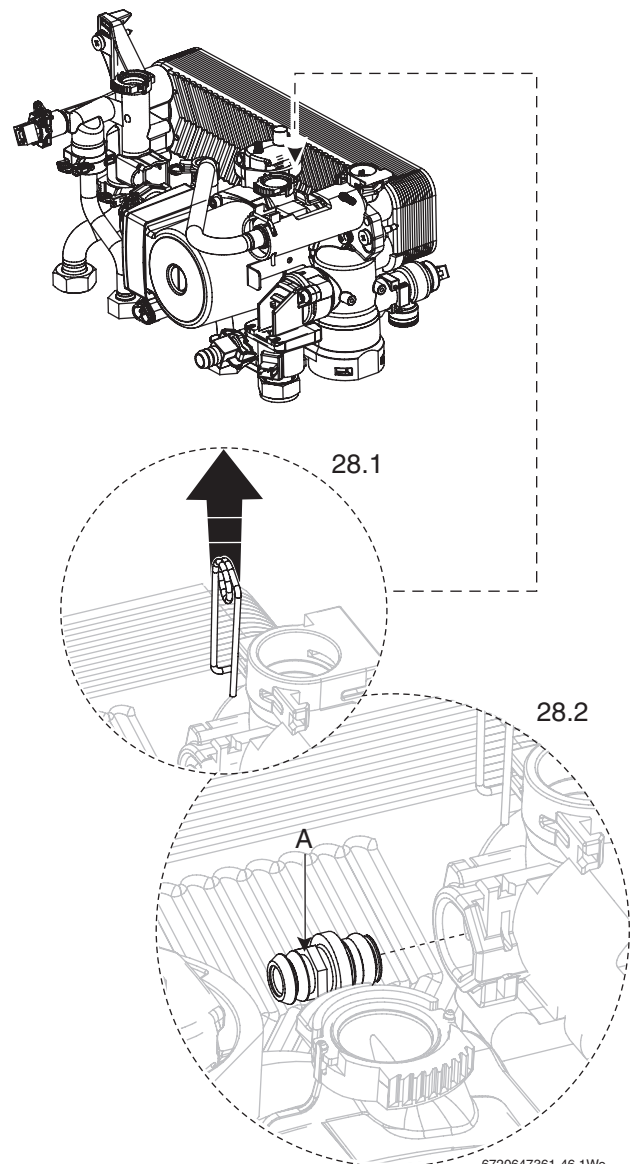

Fig. 79 Plastic protection device removal

29. DHW HEAT EXCHANGER

- ▶ Remove the Hydraulic block from the boiler (See Removing the Hydraulic Block).
- ▶ Undo the two screws (B) securing the plastic housings to the heat exchanger.
- ▶ Remove the heat exchanger.
- ▶ To refit, follow the above in reverse.
- ▶ Ensure any seals that have been disturbed are renewed.

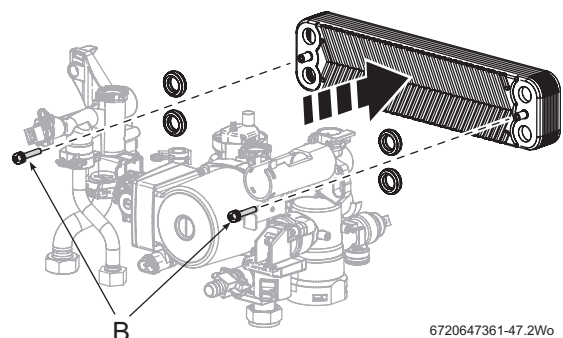

Fig. 80 DHW Heat Exchanger removal

6.4 SHORT PARTS LIST





	Fan 8 716 116 067 0 GC No. H26 536		Burner 8 718 006 658 0 GC No. E27 200		Burner skin seal 8 711 004 168 0 OGC No. E27 201
	Gas valve 8 718 221 347 0 GC No. H56-469		Temperature limit sensor 8 722 963 858 0 GC No. H08 291		Set of electrodes including seal 8 718 107 089 0 GC No. H22 458
	Flow reg. Type E 11 litre - brown 8 716 107 044 0		Flow reg. Type E 12 litre - red 8 716 141 061 0		Flow reg. Type E 14 litre - pink 8 716 107 887 0
	Flow reg. Type E 15litre - lime green 8 716 141 031 0 GC No. H31 959		Pump assembly 8 716 106 354 0 GC No. H22 463		Pressure gauge 8 718 224 344 0 GC No. H02 528
	Flow sensor 8 716 115 754 0 GC No. H02 529		DHW temperature sensor 8 714 500 081 0 GC No. H02 538		Heat exchanger 16 plate 8 716 106 685 0 GC No. H02 531
	Heat exchanger 20 plate 8 716 108 212 0 GC No. H22 465		Control unit 8 737 703 196 0		Bearing plate (Fan intake diaphragm) 8 715 505 883 0
	Diverter valve assembly 8 716 106 845 0 GC No. H02 533		Diverter valve motor 8 716 106 847 0 GC No. H02 534		Control sensor - primary 8 714 500 087 0 GC No. E74 536
	Heat Exchanger inspection cover seal 8 710 103 153 0		Pressure relief valve 8 716 106 431 0 GC No. H09 750		Auto Air Vent 8 716 106 445 0
	Flue overheat thermostat 8 710 506 267 0		Flue sample plug air intake 8 716 111 253 0		Flue sample plug 8 716 111 252 0

Table 11 Short parts list

7 FAULT FINDING & DIAGNOSIS

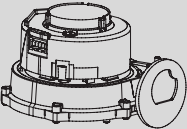
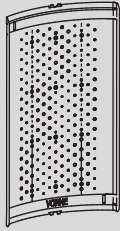
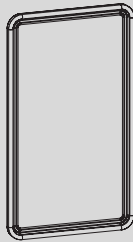
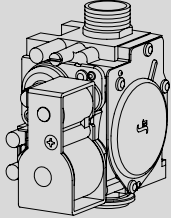
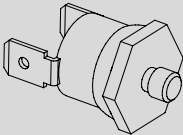
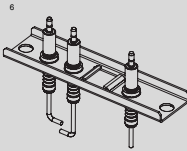
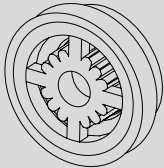
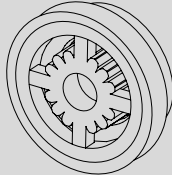
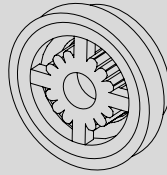
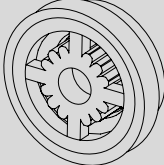
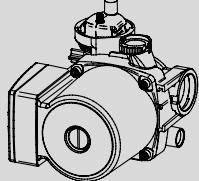
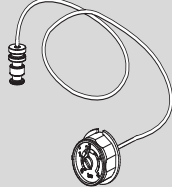
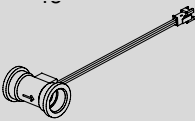
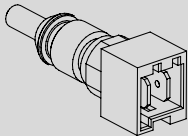
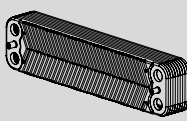
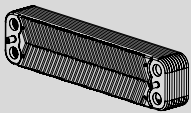
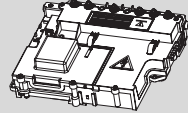
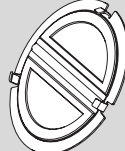
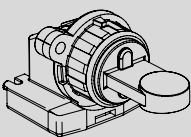
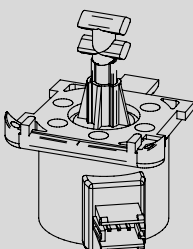
7.1 FAULT FINDING

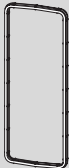
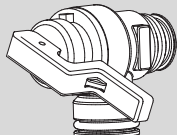
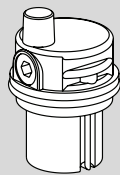
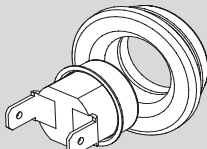

This fault finding information is for guidance only. Worcester, Bosch Group cannot be held responsible for costs incurred by persons not deemed to be competent.

The electronic control system for this boiler incorporates a blue central indicator. This normally confirms the permanent mains supply but, by flashing during a fault. The seven segment display on the boiler fascia give an alpha numeric fault code. Use the table below to identify the fault code and cause.

A more detailed fault finding procedure is described in the Service Engineer's booklet 8 716 115 748.

This fault finding system assumes that the appliance has been operating normally until the time of failure (i.e. not a first installation error).

PRELIMINARY CHECKS: Preliminary electrical system checks are the first electrical checks to be carried out during a fault-finding procedure. On completion of the Service/Fault-Finding task which has required the breaking and remaking of electrical connections, check:

- (a) EARTH CONTINUITY
- (b) SHORT CIRCUIT CHECK
- (c) POLARITY
- (d) RESISTANCE TO EARTH

Display code	Description	Remedy
A1	Pump has run dry or pump has stalled/seized.	Check for water leaks. Free the pump or replace.
A7	Hot water NTC sensor defective.	Check: - hot water NTC sensor - connecting lead for circuit breaks/short circuits.
A8	Break in communication to TD200 or/and RT10.	Check electrical connections.
b1	Code plug not detected.	Insert code plug correctly, test and replace if necessary.
C6	Fan speed too low.	Check: fan lead and connector, and fan; replace as necessary.
E2	CH flow NTC sensor defective.	Check CH flow NTC sensor and connecting lead.
E9	Safety temp. limiter in CH flow has tripped.	Check: - system pressure, - safety temp. limiters, - pump operation, - fuse on pcb, bleed appliance.
EA	Flame not detected.	Is gas cock turned on? Check: - gas supply pressure, - power supply, - igniter electrode and lead, - ionisation sensing electrode and lead, - flue duct and CO2 level.
F0	Internal error.	Check electrical connector contacts, programmer interface module ignition leads are not loose; replace pcb if necessary.
F7	Flame detected even though appliance switched off.	Check: - electrode assembly, - dry pcb. - Flue clear?
FA	Flame detected after gas shut off.	Check: - gas valve ; resistance, coil 1 = 190 Ω, coil 2 = 390 Ω - wiring to gas valve. Clean condensation trap and check electrode assembly. Flue clear?
Fd	Reset button pressed by mistake.	Press reset button again.

Table 12

7.2 CENTRAL HEATING FUNCTION

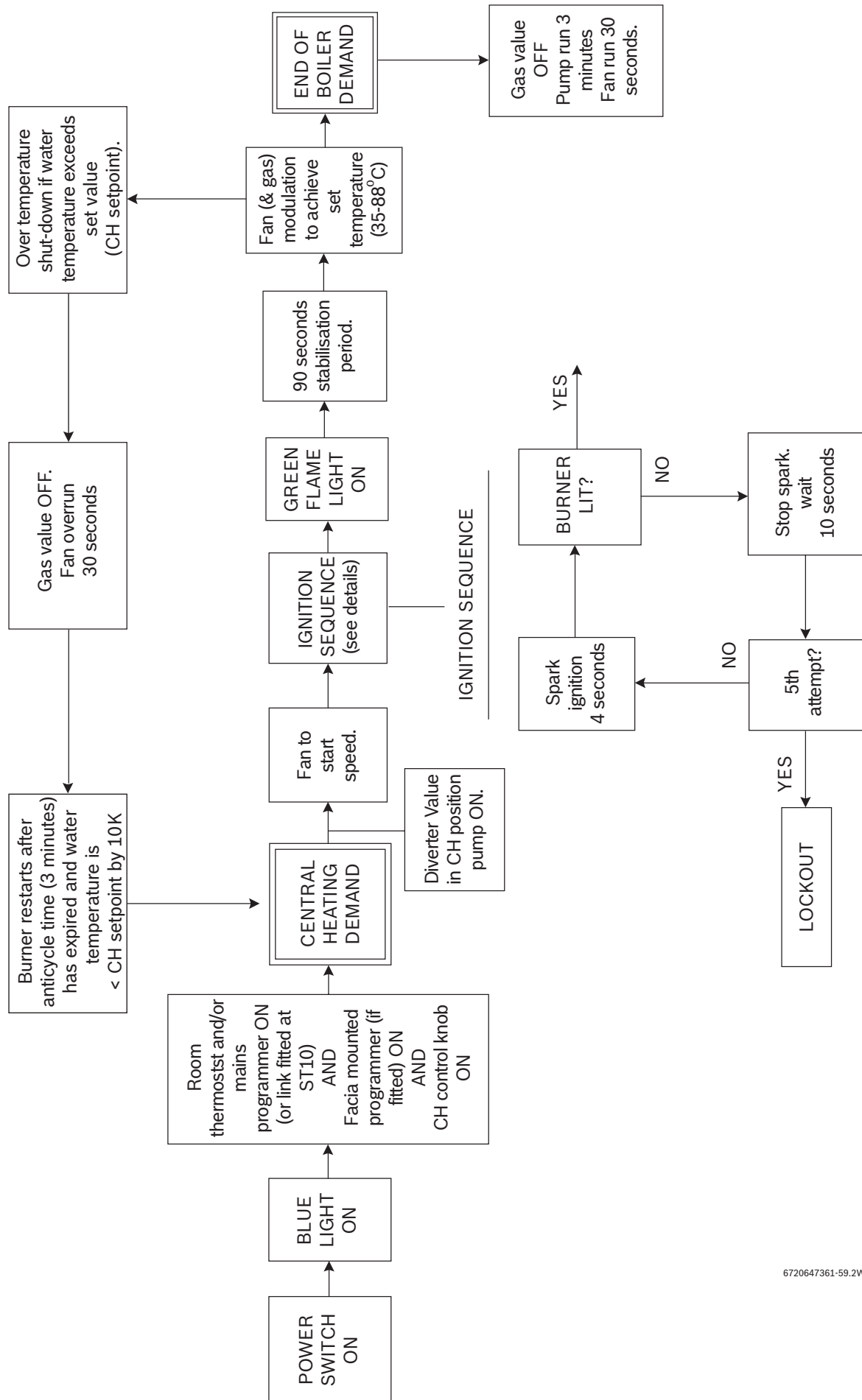

6720647361-59.2Wo

7.3 PREHEAT AND DHW FUNCTION

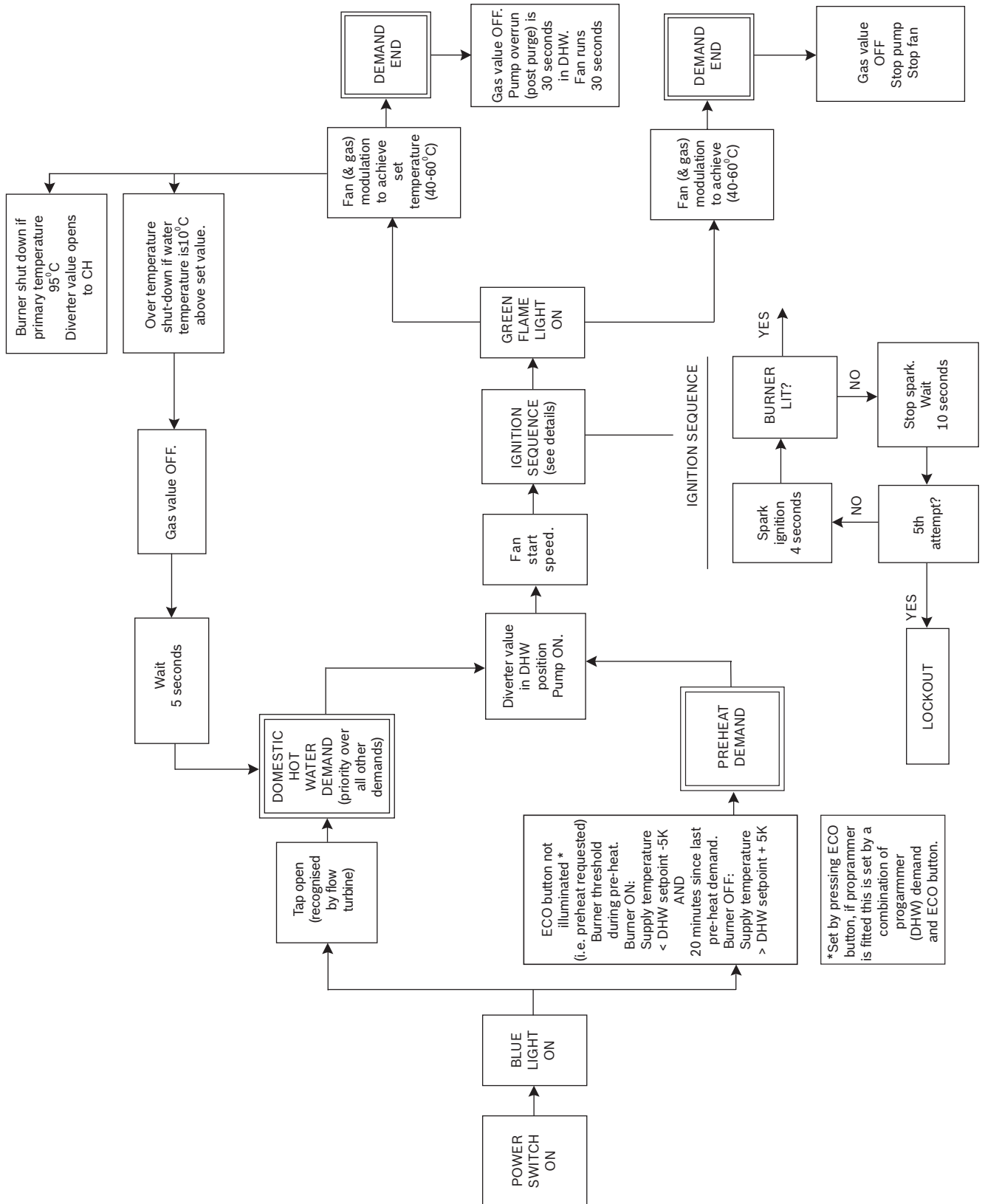

*Set by pressing ECO button, if programmer is fitted this is set by a combination of programmer (DHW) demand and ECO button.

6720647361-60.2Wo

7.4 PROTECTION FUNCTION

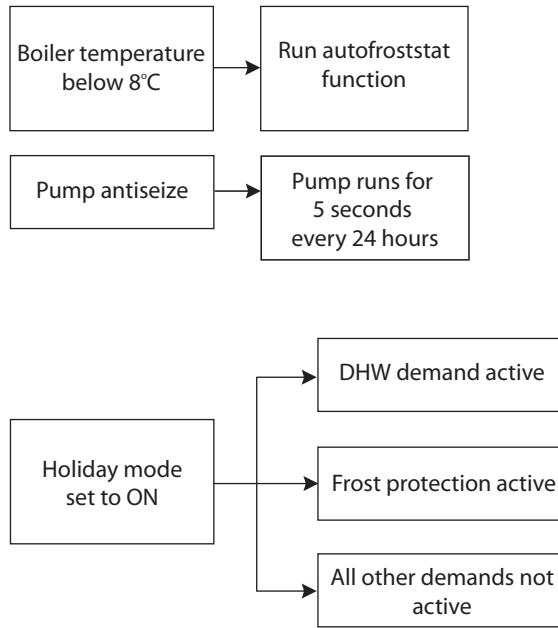

6720647361-61.1Wo

Service Record

It is recommended that your heating system is serviced regularly and that the appropriate Service Interval Record is completed.

Service Provider

Before completing the appropriate Service Record below, please ensure you have carried out the service as described in the manufacturer's instructions.

Always use the manufacturer's specified spare part when replacing controls.

Service 1

Date: _____

Engineer Name: _____

Company Name: _____

Telephone No. _____

Gas Safe Register No. _____

Comments: _____

Signature: _____

Service 2

Date: _____

Engineer Name: _____

Company Name: _____

Telephone No. _____

Gas Safe Register No. _____

Comments: _____

Signature: _____

Service 3

Date: _____

Engineer Name: _____

Company Name: _____

Telephone No. _____

Gas Safe Register No. _____

Comments: _____

Signature: _____

Service 4

Date: _____

Engineer Name: _____

Company Name: _____

Telephone No. _____

Gas Safe Register No. _____

Comments: _____

Signature: _____

Service 5

Date: _____

Engineer Name: _____

Company Name: _____

Telephone No. _____

Gas Safe Register No. _____

Comments: _____

Signature: _____

Service 6

Date: _____

Engineer Name: _____

Company Name: _____

Telephone No. _____

Operative ID No. _____

Comments: _____

Signature: _____

Service 7

Date: _____

Engineer Name: _____

Company Name: _____

Telephone No. _____

Gas Safe Register No. _____

Comments: _____

Signature: _____

Service 8

Date: _____

Engineer Name: _____

Company Name: _____

Telephone No. _____

Gas Safe Register No. _____

Comments: _____

Signature: _____

Service 9

Date: _____

Engineer Name: _____

Company Name: _____

Telephone No. _____

Gas Safe Register No. _____

Comments: _____

Signature: _____

Service 10

Date: _____

Engineer Name: _____

Company Name: _____

Telephone No. _____

Gas Safe Register No. _____

Comments: _____

Signature: _____

Worcester, Bosch Group
Cotswold Way, Warndon, Worcester WR4 9SW.
Tel. 0844 892 9900

Worcester, Bosch Group is a brand name of Bosch Thermotechnology Ltd.
worcester-bosch.co.uk

6 720 803 599 (2012/06)

WORCESTER, BOSCH GROUP:

TECHNICAL SUPPORT:	0844 892 3366
APPOINTMENTS:	0844 892 3000
SPARES:	01905 752571
LITERATURE:	0844 892 9800
TRAINING:	01905 752526
SALES:	01905 752640



WORCESTER
Bosch Group